











Digital electropneumatic Process Controller SideControl

- Compact and robust design
- Start-up via the TUNE function of the positioner and process controller
- Integrated diagnostic functions for valve monitoring
- Dynamic actuating system with no air consumption in controlled state
- EtherNet/IP, PROFINET, Modbus TCP, PROFIBUS DP-V1 or Bürkert system bus (büS)

Product variants described in the data sheet may differ from the product presentation and description.

Can be combined with

	Type 8805 ▶ Ball valve / Butterfly valve with pneumatic rotary actuator
	Type 8202 ▶ pH or redox potential transmitter, ELEMENT design
	Type 8045 ▶ Magnetic inductive Insertion flowmeter
	Type 8798 ▶ Remote sensor for pneumatically actuated process valves
	Type 2301 ▶ Pneumatically operated 2-way Globe Control Valve
	Type 2300 ▶ Pneumatically operated 2-way angle seat control valve ELEMENT
	Type 2103 ▶ 2/2-way diaphragm valve with pneumatic stainless steel actuator (Type ELEMENT) for decentralised automation
	Type 8619 ▶ multiCELL – Multi-channel and multi-function transmitter/controller

Type description

The device Type 8793 digital process controller is designed with standardisation according to IEC 60534-6-1 or VDI/VDE 3845 (IEC 60534-6-2) for assembly to linear and rotary actuators. The variant with remote position sensor can also be used to control Bürkert process control valves. The process controller processes all standard current and voltage signals and can also be equipped with the fieldbus interface. The actual process value is supplied directly to the device as 4-20 mA, PT100 or as a frequency signal. The process controller calculates the position setpoint for the subordinated positioner via variance comparison. The parameterisation of process and position controllers can be carried out automatically via the Tune function. Operation is simple via the graphical display with keypad or via Bürkert Communicator. The process controller is equipped with diagnostic functions to monitor the valve. The diagnostics can be used to monitor the operating conditions of the control valve which makes maintenance decisions predictable and optimises the availability of the plants as required. The pneumatic actuating system can be used equally for single-acting and double-acting actuators. It is characterised by a defined safety response in the event of the failure of the electrical or pneumatic auxiliary power and possesses an enormous air capacity range with pressure supply up to 7 bar.

Table of contents

1. General technical data	4
1.1. Process controller SideControl Type 8793.....	4
1.2. Linear remote position sensor (ELEMENT Type 8798).....	6
1.3. Rotative remote position sensor (NAMUR).....	6
1.4. Position feedback with proximity switches (accessories for retrofitting).....	7
2. Approvals and conformities	8
2.1. General notes.....	8
2.2. Conformity.....	8
2.3. Standards.....	8
2.4. Explosion protection.....	8
Positioner SideControl Type 8793.....	8
2.5. North America (USA/Canada).....	8
Positioner SideControl Type 8793.....	8
Linear position sensor, remote (ELEMENT Type 8798).....	8
Rotative position sensor, remote (NAMUR Type 8798).....	8
2.6. Others.....	9
China Compulsory Certification (CCC).....	9
3. Dimensions	10
3.1. NAMUR version.....	10
3.2. Remote version.....	11
3.3. Mounting specification of NAMUR/Remote Version.....	12
NAMUR version.....	12
Remote version.....	12
3.4. ATEX/IECEx version.....	13
3.5. Remote position sensor version.....	13
3.6. Mounting on control valve according to NAMUR.....	14
4. Device/Process connections	15
4.1. Electrical connections.....	15
Multipole connection.....	15
PROFIBUS DP Connection.....	19
EtherNet/IP, PROFINET, Modbus TCP connection.....	20
Bürkert system bus (bÜS) connection.....	21
5. Performance specifications	23
5.1. Signal flow diagram.....	23
Process control loop.....	23
Position control loop.....	23
Additional software options of process controller SideControl Type 8793 (extract).....	23
5.2. Interface diagram.....	24
Version without fieldbus communication.....	24
Version with fieldbus communication.....	24
6. Product installation	25
6.1. Mounting options.....	25
NAMUR version.....	25
Remote version.....	26
Position feedback with proximity switches.....	27
6.2. Combination possibilities with pneumatic process valves.....	28

DTS 1000121144 EN Version: AH Status: RL (released | freigegeben | validé) printed: 07.03.2024

7. Ordering information	29
7.1. Bürkert eShop	29
7.2. Bürkert product filter	29
7.3. Ordering chart	29
Process controller SideControl Type 8793 NAMUR version	29
Process controller SideControl Type 8793, remote version	29
Remote position sensor for remote version of SideControl Type 8793	30
7.4. Ordering chart accessories	31
Standard accessories	31
Accessories SideControl NAMUR	31
Accessories SideControl Remote	31

DTS 1000121144 EN Version: AH Status: RL (released | freigegeben | validé) printed: 07.03.2024

1. General technical data

1.1. Process controller SideControl Type 8793

Product properties	
Dimensions	Further information can be found in chapter "3. Dimensions" on page 10.
Material	
Housing	Aluminium, plastic-coated
Seal	EPDM, NBR, FKM
Operation	
Display	Graphic display with backlight and intuitive menu navigation
Operating keys	Membrane keypad with 4 keys
Service interface	Connected to PC via USB connection
Configuration tool	Bürkert Communicator PACTware (only for device versions with PROFIBUS)
Commissioning	
Initialisation positioner/process controller	Automatic by P.TUNE function (self-optimization of PID parameters)
Status display	
Optical position indicator (mechanical)	Integrated (for NAMUR version)
Communication	
Fieldbus	EtherNet/IP, PROFINET, Modbus TCP, PROFIBUS DP-V1
Digital	Bürkert system bus (bÜS) (based on CANopen)
Performance data	
Position sensor	
Integrated position sensor (NAMUR)	Conductive plastic rotary potentiometer
External remote position sensor	Linear or rotative
Measuring range for rotary actuator	
PROFIBUS	Rotation angle: 30°...150°
EtherNet/IP, PROFINET, Modbus TCP and bÜS	Rotation angle: 30°...180°
Stroke range for linear actuator	3...130 mm, depending on the lever of the attachment kit
Electrical data	
Operating voltage	24 V DC \pm 10 %
Residual ripple	Max. 10 %
Power consumption	< 5 W
Protection class	III according to DIN EN 61140
Input /Output	
Digital input	1 digital input, 0...5 V = log "0", 10...30 V = log "1"
Digital output	2 digital outputs (optional), galvanically isolated
Current limitation	100 mA, output will be synchronised when overloaded
Analogue output	1 output (optional) 0/4...20 mA, 0...5/10 V
In-/Output data setpoint and actual value	
Setpoint signal	
Setpoint setting	0/4...20 mA 0...5/10 V
Input resistance	0/4...20 mA: 70 Ω 0...5/10 V: 20 k Ω
Actual value signal	
Setting 4...20 mA	70 Ω input resistance/resolution 12 bit
Frequency setting	20 k Ω input resistance, 0...1000 Hz/1 % f reading of input frequency range, input signal > 300 mV _{ss} sine, rectangle, triangle
Setting Pt 100	Measuring range -20...+220 °C, resolution < 0.1 °C
Electrical connection	
Multipole version	Screw terminals: M8, M12 according to device version (see connection description)
Cable gland version	2x M20 \times 1.5 (cable \varnothing 6...12 mm) on screw terminals (0.14...1.5 mm ²)
Remote version	1x M12 \times 1.5 (cable \varnothing 3...6.5 mm)

Pneumatic data	
Control medium	Neutral gases, air, quality class according to ISO 8573-1
Dust content	Class 7 (<40 µm particle size)
Particle density	Class 5 (<10 mg/m ³)
Pressure dew point	Class 3 (<-20 °C)
Oil content	Class X (<25 mg/ m ³)
Air supply filter	Exchangeable
Mesh size	~0.1 mm
Supply pressure	1.4...7 bar ^{1,2)}
Pilot air port	Threaded port G ¼
Positioning system	
Universal air capacity	
Single and double acting	50 l _N /min (at 1.4 bar ²⁾) for aeration and ventilation 150 l _N /min (at 6 bar ²⁾) for aeration and ventilation Q _{Nn} = 100 l _N /min
Low air capacity	
Single acting	Q _{Nn} = 7 l _N /min (Q _{Nn} according to definition at pressure drop from 7 to 6 bar abs)
Approvals and conformities	
Explosion protection	
Ignition protection class	II 3D Ex tc IIIC T135 °C Dc II 3G Ex ec IIC T4 Gc
ATEX	BVS 16 ATEX E 118 X II 3G Ex ec ic IIC T4 Gc II 3D Ex tc IIIC T135 °C Dc
IECEX	IECEX BVS 16.0091 X Ex ec ic IIC T4 Gc Ex tc IIIC T135 °C Dc
Further information can be found in chapter "2.4. Explosion protection" on page 8.	
North America (USA/Canada)	
CSA for Canada and the USA	UL 429 (Electrically operated valves) CSA C22.2 No. 139 (Electrically operated valves) Further information can be found in chapter "2.5. North America (USA/Canada)" on page 8.
Others	
China Compulsory Certification (CCC)	The products with Ex approval are suitable for import and use for hazardous applications in China. Further information can be found in chapter "2.6. Others" on page 9.
Further information can be found in chapter "2. Approvals and conformities" on page 8.	
Environment and installation	
Operating conditions	
Ambient temperature	
With ATEX/IECEX approval	0...+60 °C
Without Ex approval	-10...+60 °C
Degree of protection	IP65/IP67 according to EN 60529, 4X according to NEMA 250 Standard
Operating altitude	Up to 2000 m above sea level
Installation and mechanical data	
Mounting variant	NAMUR according to IEC 60534 - 6 - 1 resp. VDI/VDE 3845 (IEC 60534 - 6 - 2), remote
Installation position	As required, display above or laterally
Valve actuator (type, size)	Rotary and linear actuators according to NAMUR, ELEMENT Type 2301, 2300 (actuator size Ø 70/90/130/225 mm) and CLASSIC (actuator size Ø 175/225 mm) in combination with remote version
Adapter kit	Further information can be found in chapter "7.4. Ordering chart accessories" on page 31.

1.) Supply pressure has to be 0.5...1 bar above the minimum required pilot pressure for the valve actuator.

2.) Pressure data: overpressure to atmospheric pressure

1.2. Linear remote position sensor (ELEMENT Type 8798)

Note:

When mounting the remote positioner away from the actuator, the length of the pneumatic control lines influences the dynamics and accuracy of the position control loop. The length of the control air lines should therefore be as short as possible.

Product properties	
Actual position signal	Digital (RS485)
Detection range of the sensor	3...45 mm (stroke range of valve spindle)
Electrical data	
Operating voltage	24 V DC \pm 10 %
Protection class	III according to DIN EN 61140
Power consumption	<0.3 W
Electrical connection	
Cable gland (cable length)	1x M16 \times 1.5 (cable \varnothing 5...10 mm) on screw terminals (0.14...1.5 mm ²)
Connection cable	10 m
Approvals and conformities	
Protection class	IP65 and IP67 according to EN 60529, 4X according to NEMA 250 standard
Explosion protection	
Ignition protection class	II 3G Ex ec IIC T4 Gc II 3D Ex tc IIIC T135 °C Dc
Further information can be found in chapter “2.4. Explosion protection” on page 8.	
North America (USA/Canada)	
UL Recognized for the USA and Canada	cULus certificate: 238179 Further information can be found in chapter “2.5. North America (USA/Canada)” on page 8.
Others	
China Compulsory Certification (CCC)	The products with Ex approval are suitable for import and use for hazardous applications in China. Further information can be found in chapter “2.6. Others” on page 9.
Further information can be found in chapter “2. Approvals and conformities” on page 8.	
Environment and installation	
Ambient temperature	-25...+80 °C

1.3. Rotative remote position sensor (NAMUR)

Note:

When mounting the remote positioner away from the actuator, the length of the pneumatic control lines influences the dynamics and accuracy of the position control loop. The length of the control air lines should therefore be as short as possible.

Product properties	
Stroke range when mounted to linear actuator	3...130 mm, depending on the lever of the attachment kit
Actual position signal	Digital (RS485)
Measuring range	Rotation angle 30°...180°
Electrical data	
Operating voltage	10...30 V DC
Protection class	III according to DIN EN 61140
Power consumption	<0.8 W
Electrical connection	2 m round cable (shielded)
Approvals and conformities	
Protection class	IP65 according to EN 60529
North America (USA/Canada)	
UL Recognized for the USA and Canada	cULus certificate: E226909 Further information can be found in chapter “2.5. North America (USA/Canada)” on page 8.
Further information can be found in chapter “2. Approvals and conformities” on page 8.	
Environment and installation	
Ambient temperature	-25...+80 °C

1.4. Position feedback with proximity switches (accessories for retrofitting)

Note:

The feedback unit possesses 2 proximity switches that can be adjusted independently of each other via switch flags.

Product properties	
Output function	3-wire, normally open contact, PNP
Electrical data	
Electrical connection	M12, 4-pin
Operating voltage	10...30 V DC
Protection class	III according to DIN EN 61140
DC-rated current	≤ 100 mA
Residual ripple	≤ 10 % U _{ss}
Approvals and conformities	
Degree of protection	IP65 and IP67
Further information can be found in chapter "2. Approvals and conformities" on page 8.	

2. Approvals and conformities

2.1. General notes

- The approvals and conformities listed below must be stated when making enquiries. This is the only way to ensure that the product complies with all required specifications.
- Not all available versions can be supplied with the below mentioned approvals or conformities.

2.2. Conformity



In accordance with the Declaration of Conformity, the product is compliant with the EU Directives.

2.3. Standards

The applied standards which are used to demonstrate compliance with the EU Directives are listed in the EU-Type Examination Certificate and/or the EU Declaration of Conformity.

2.4. Explosion protection

Positioner SideControl Type 8793

Approval	Description
 	<p>Optional: Explosion protection</p> <p>ATEX: BVS 16 ATEX E 118 X II 3G Ex ec ic IIC T4 Gc II 3D Ex tc IIIC T135 °C Dc</p> <p>IECEX: IECEX BVS 16.0091 X Ex ec ic IIC T4 Gc Ex tc IIIC T135 °C Dc</p>

2.5. North America (USA/Canada)

Positioner SideControl Type 8793

Approval	Description
 C US	<p>Optional: CSA for Canada and the USA</p> <p>The products are CSA approved for Canada and the USA according to:</p> <ul style="list-style-type: none"> • UL 429 (Electrically operated valves) • CSA C22.2 No. 139 (Electrically operated valves)

Linear position sensor, remote (ELEMENT Type 8798)

Approval	Description
	<p>Optional: UL Listed for the USA and Canada</p> <p>The products are UL Listed for the USA and Canada according to:</p> <ul style="list-style-type: none"> • UL 61010-1 (ELECTRICAL EQUIPMENT FOR MEASUREMENT, CONTROL, AND LABORATORY USE – Part 1: General Requirements) • CAN/CSA-C22.2 No. 61010-1

Rotative position sensor, remote (NAMUR Type 8798)

Approval	Description
	<p>Optional: UL Listed for the USA and Canada</p> <p>The products are UL Listed for the USA and Canada according to:</p> <p>Certificate no.: E226909</p>

DTS 1000121144 EN Version: AH Status: RL (released | freigegeben | validé) printed: 07.03.2024

2.6. Others

China Compulsory Certification (CCC)

Positioner SideControl Type 8793 and linear position sensor, remote (ELEMENT Type 8798)

Conformity	Description
	Optional: China Compulsory Certification (CCC) The products with Ex approval are suitable for import and use for hazardous applications in China.

3. Dimensions

3.1. NAMUR version

Note:

Dimensions in mm

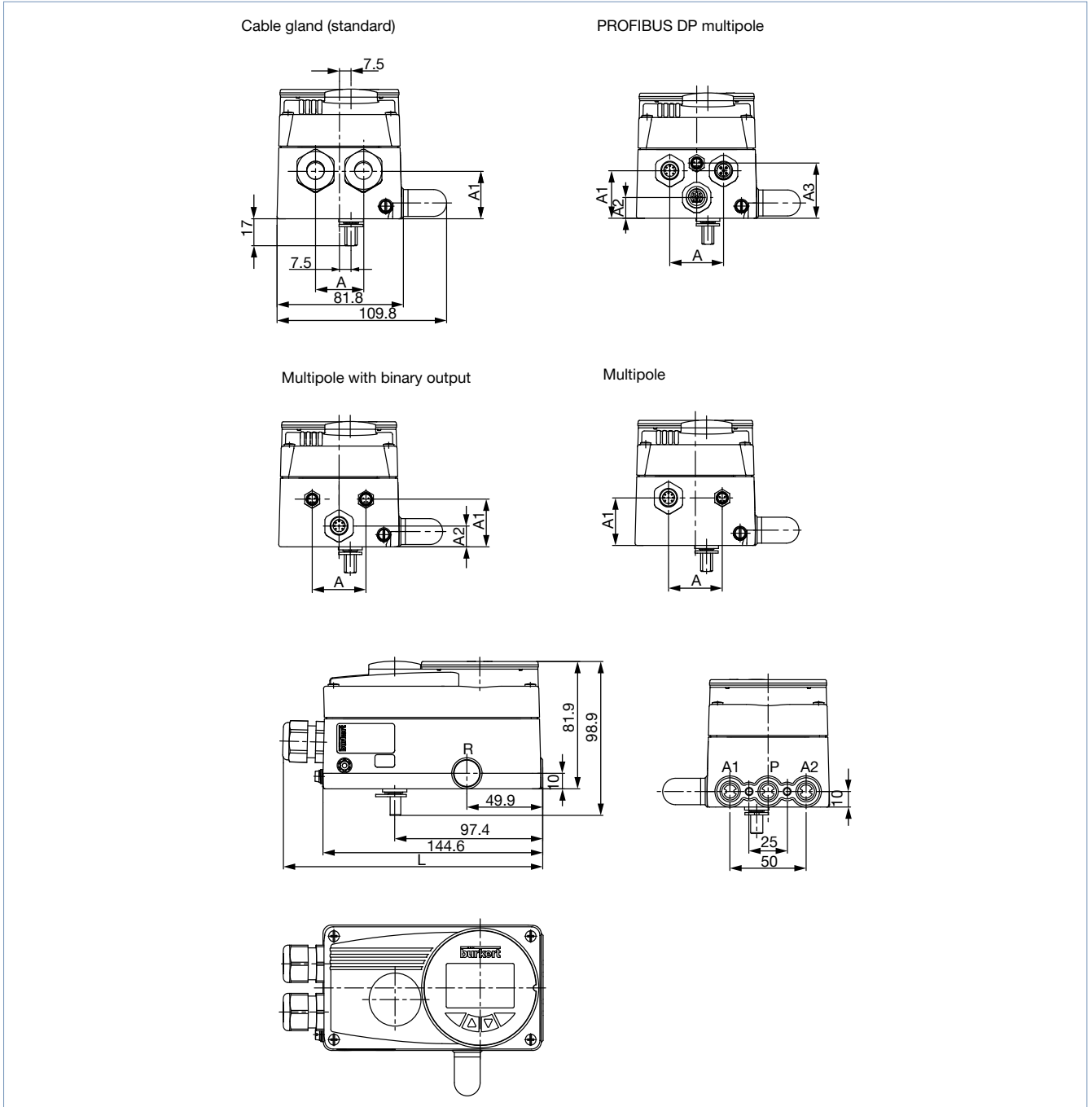

Description	L	A	A1	A2	A3
Standard	171.1	31	30	-	-
PROFIBUS DP	157.8	36	31	13.5	36.1
Multipole digital outputs	157.6	36	31	13.5	-
Multipole	157.6	36	31	-	-

DTS 1000121144 EN Version: AH Status: RL (released | freigegeben | valide) printed: 07.03.2024

3.2. Remote version

Note:

Dimensions in mm

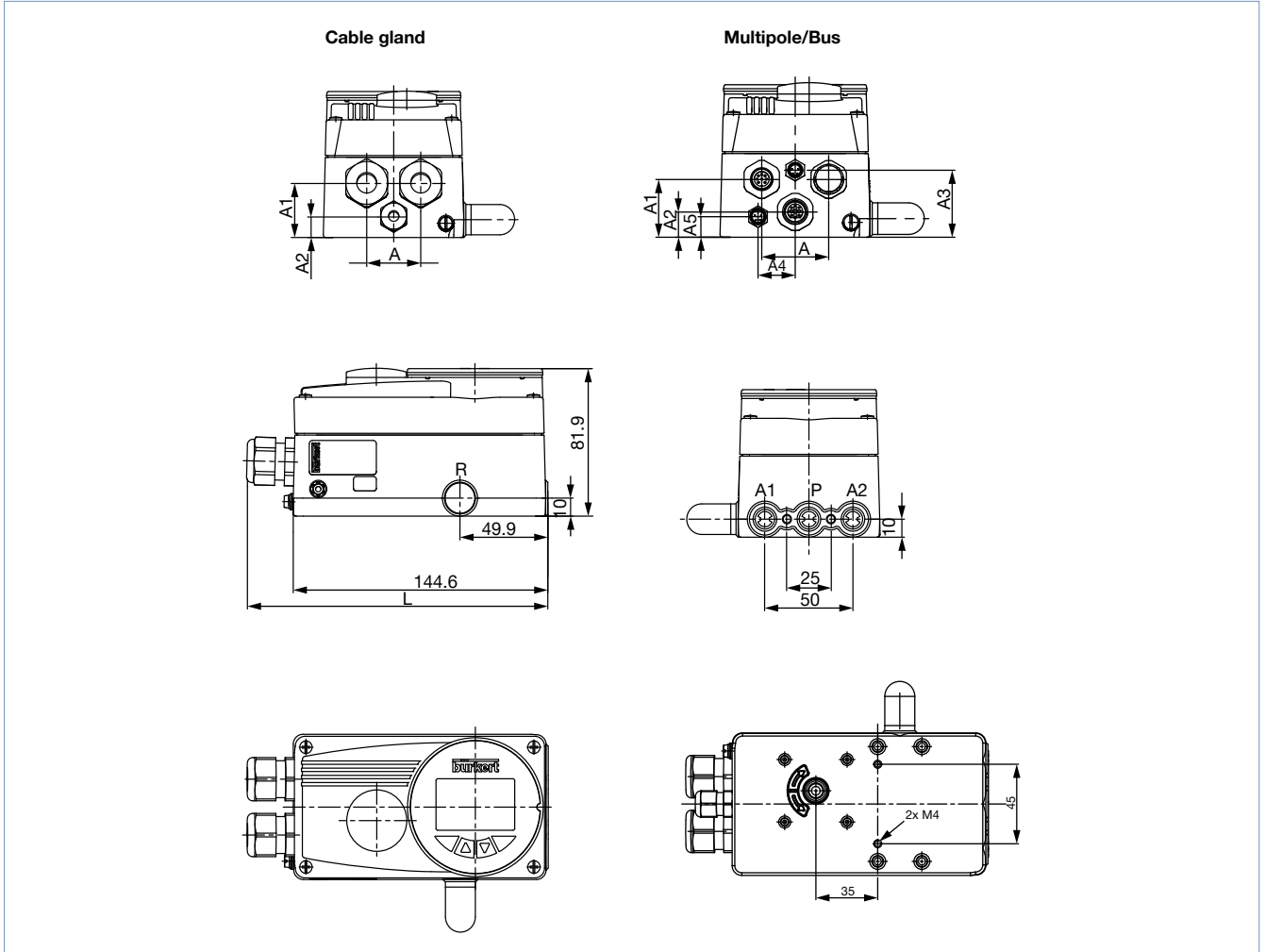

Description	L	A	A1	A2	A3	A4	A5
Remote cable gland	171.1	31	30	11.5	–	–	–
Remote multipole/bus	157.8	36	31	13.5	36	20	11

DTS 1000121144 EN Version: AH Status: RL (released | freigegeben | valide) printed: 07.03.2024

3.3. Mounting specification of NAMUR/Remote Version

Note:

- Dimensions in mm
- The rotation angle of the sensor must be within a range of 180°. ^{1.)}
- When opened up to approx. 50%, the sensor indicator should be in this position.

NAMUR version

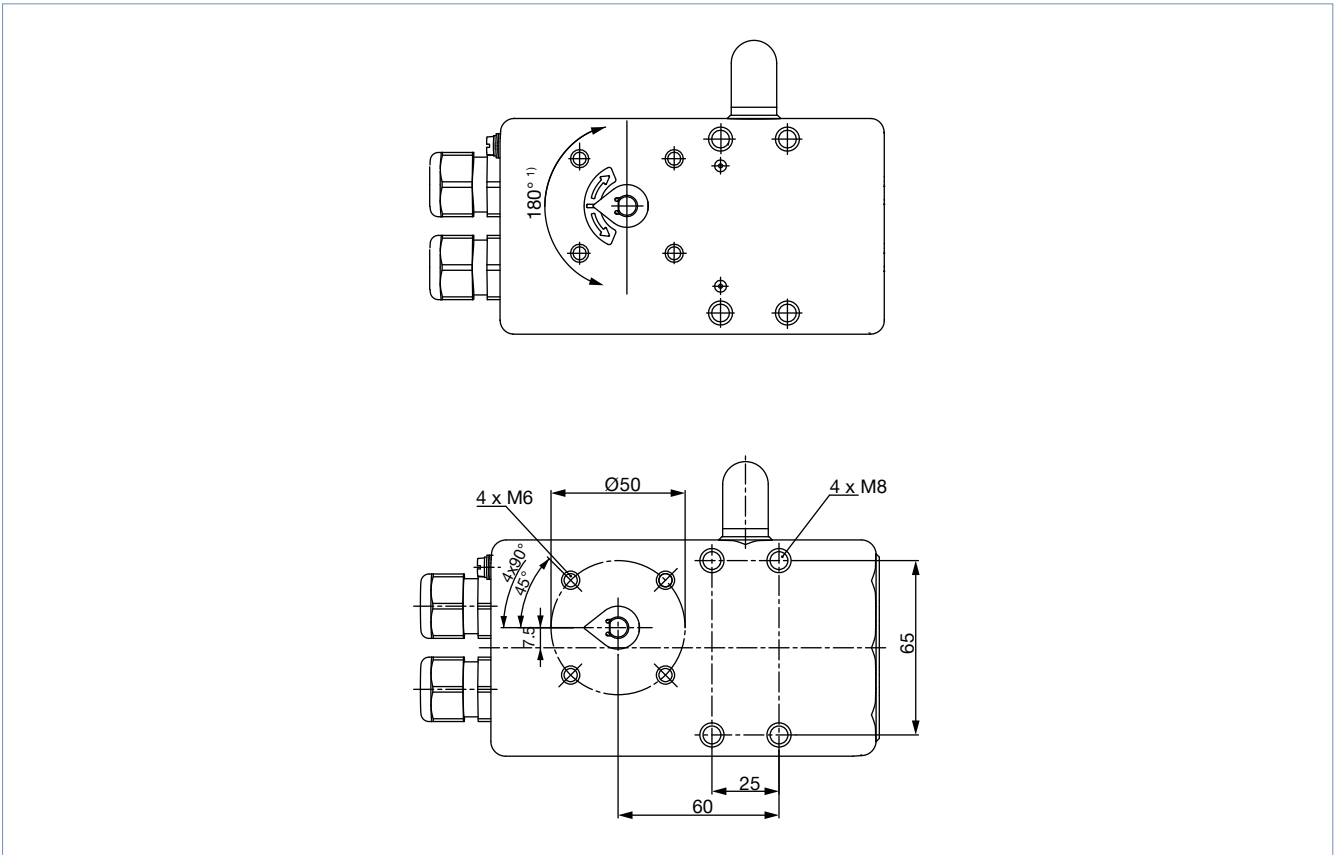

1.) Max. 180° are possible for the EtherNet/IP, PROFINET, Modbus TCP and bÜS variants, max. 150° for the other variants.

Remote version

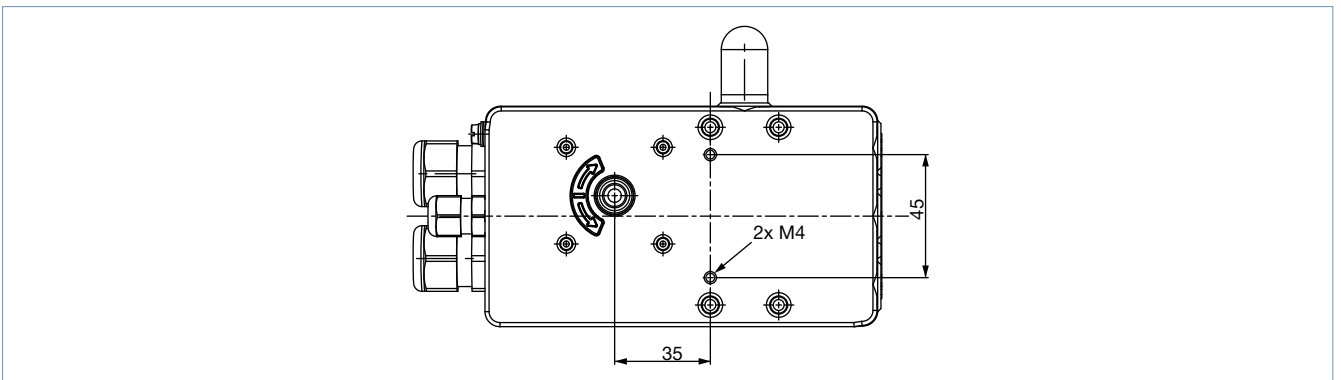

DTS 1000121144 EN Version: AH Status: RL (released | freigegeben | validé) printed: 07.03.2024

3.4. ATEX/IECEX version

Note:

Dimensions in mm

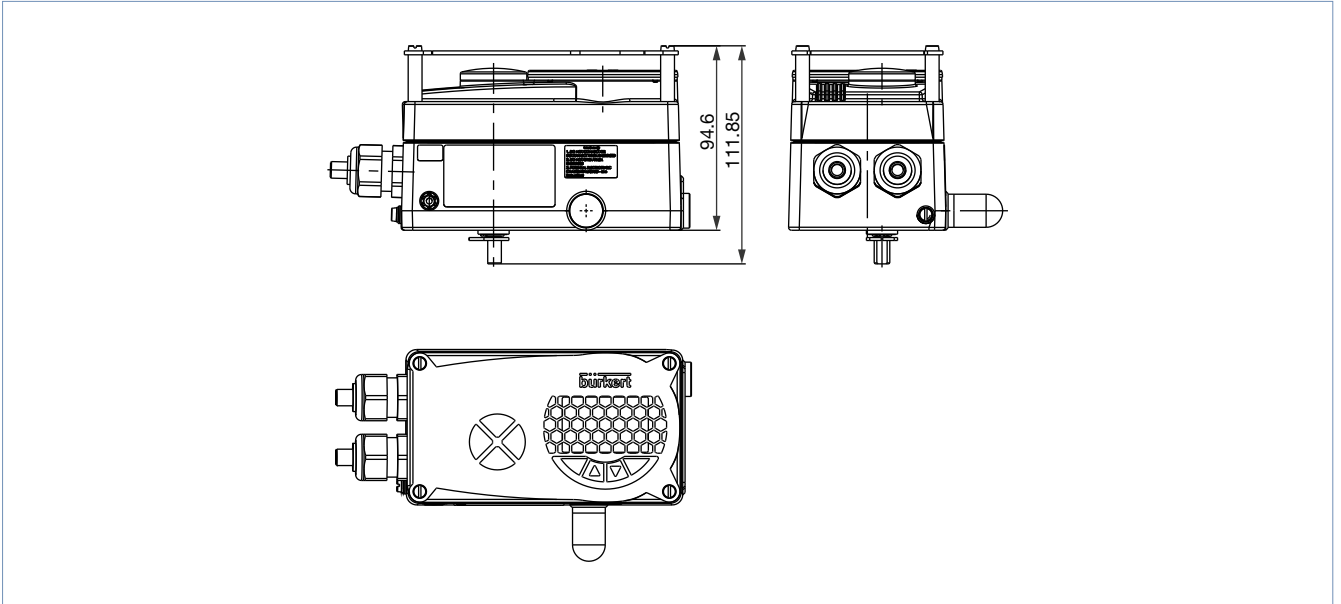

3.5. Remote position sensor version

Note:

Dimensions in mm

Linear position sensor **Type 8798** ▶ for valve position detection of Bürkert ELEMENT valves and hygienic process valves for the remote SideControl positioner .

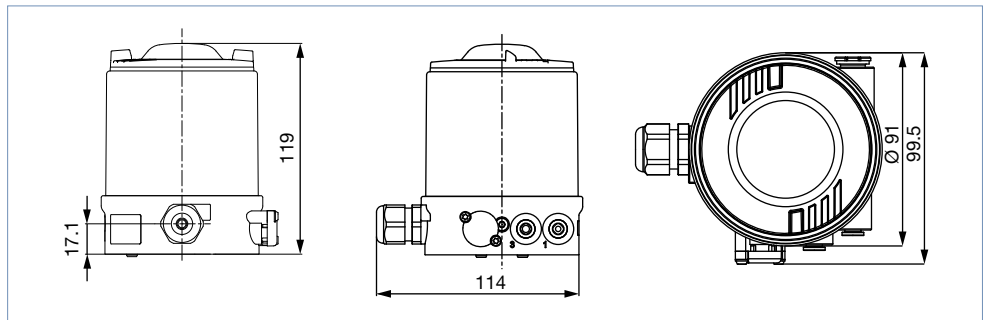

3.6. Mounting on control valve according to NAMUR

Note:

Dimensions in mm

Rotative position sensor to detect rotary motion of rotary actuators according to NAMUR/IEC 60534 - 6 - 1 and VDI/VDE 3845 (IEC 60534 - 6 - 2) for the remote SideControl positioner.

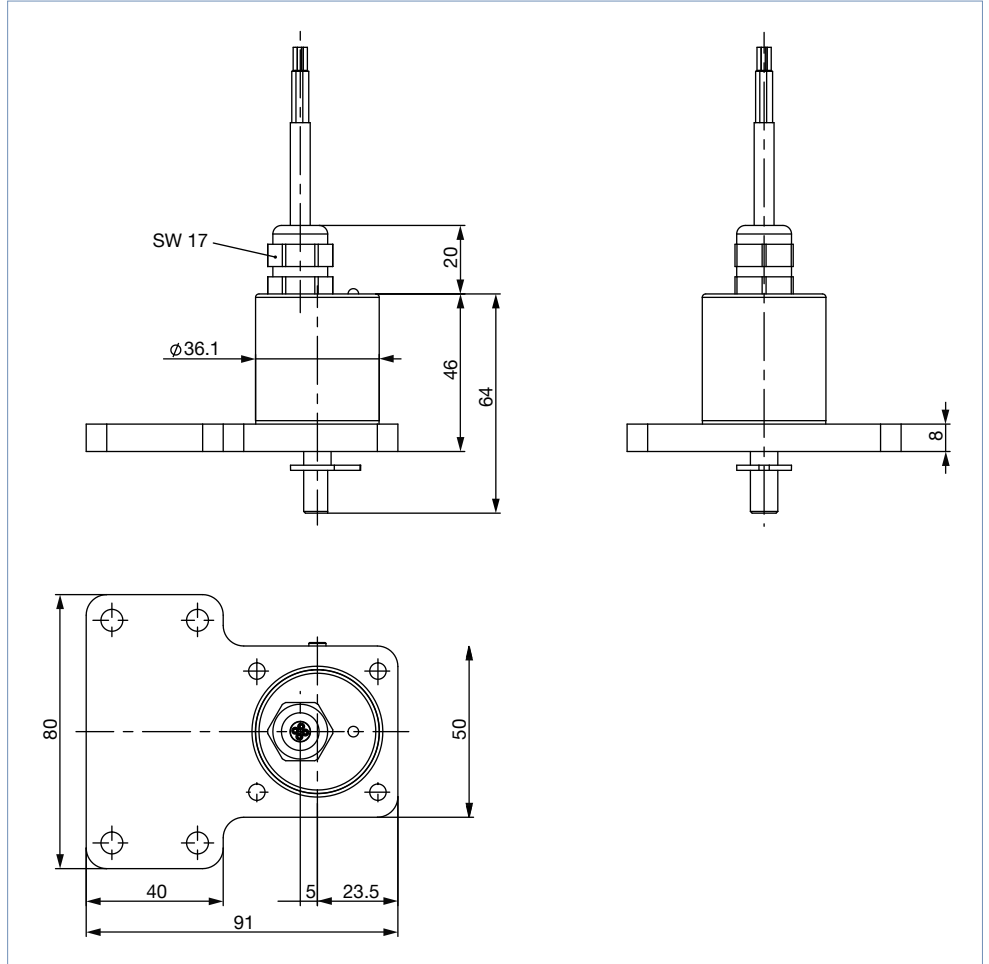

4. Device/Process connections

4.1. Electrical connections

Multipole connection

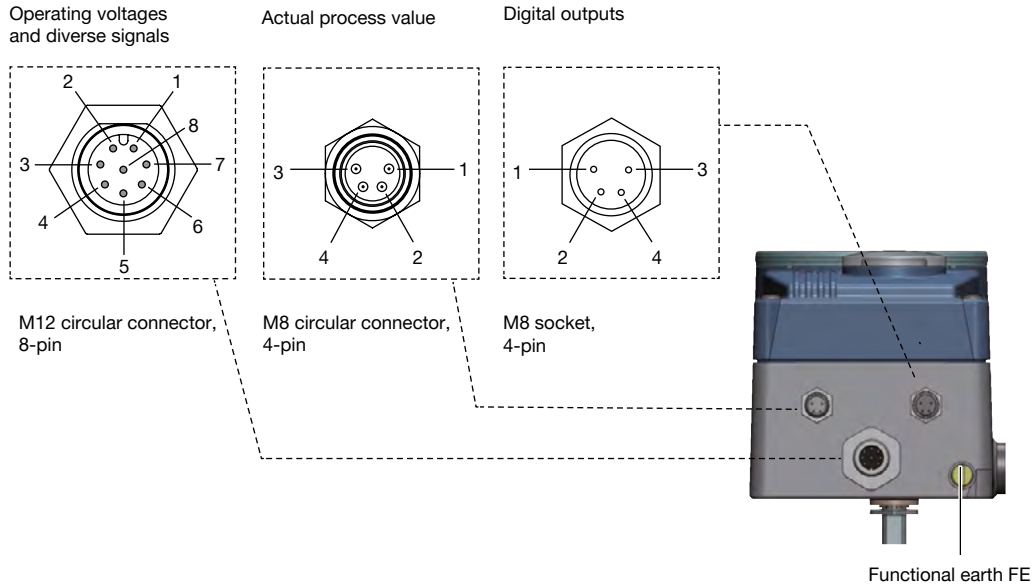

M12 circular plug, 8-pin (setpoint)

Pin	Pin assignment	Outer circuitry/Signal level	
1	Setpoint + (0/4...20 mA or 0...5/10 V)	1	+ (0/4...20 mA or 0...5/10 V) Completely galvanically isolated
2	Setpoint GND	2	GND
3	GND	3	24 V DC ± 10 % Maximum residual ripple 10 %
4	+24 V	4	
5	Digital input +	5	+ 0...5 V (log. "0") 10...30 V (log. "1")
6	Digital input GND	6	GND
Option analogue feedback			
8	Analogue feedback +	8	+ (0/4...20 mA or 0...5/10 V) Completely galvanically isolated
7	Analogue feedback GND	7	GND







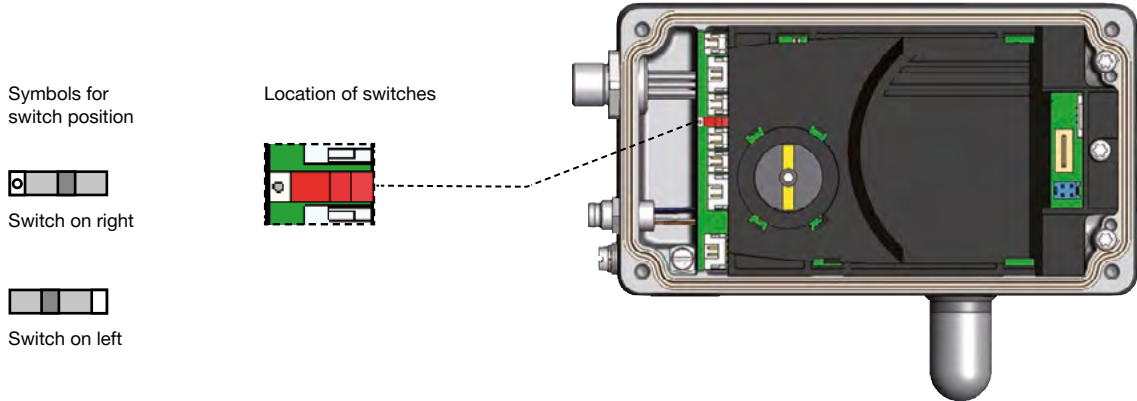

M8 socket, 4-pin (only for digital outputs options)

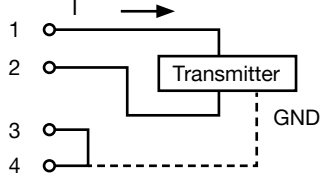
Pin	Pin assignment	Outer circuitry/Signal level	
1	Digital outputs 1	1	24 V/0 V, NC/NO Relative to operating voltage GND (terminal GND)
2	Digital outputs 2	2	24 V/0 V, NC/NO Relative to operating voltage GND (terminal GND)
3	Digital outputs GND	3	GND

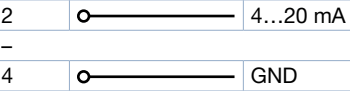
DTS 1000121144 EN Version: AH Status: RL (released | freigegeben | validé) printed: 07.03.2024

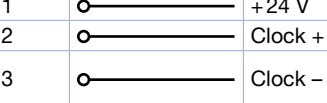
Round plug M8, 4-pin (actual process value)

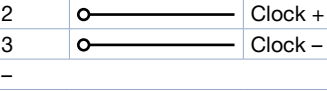

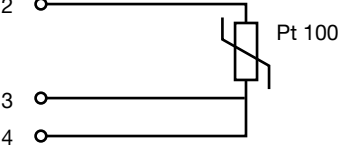
Input type ^{1.)}	Pin	Pin assignment	DIP switch	Outer circuitry
4...20 mA internally supplied	1	+24 V transmitter supply	 Switch on the left	
	2	Output from transmitter		
	3	GND identical with GND operating voltage		
	4	Bridge according to GND (GND via 3-wire transmitter)		
4...20 mA externally supplied	1	Not assigned	 Switch on the right	
	2	Process actual value +		
	3	Not assigned		
	4	Process actual value -		
Frequency internally supplied	1	+24 V sensor supply	 Switch on the left	
	2	Clock input +		
	3	Clock input - (GND identical with GND operating voltage)		
	4	Not assigned		
Frequency externally supplied	1	Not assigned	 Switch on the right	
	2	Clock input +		
	3	Clock input -		
	4	Not assigned		
Pt 100	1	Not assigned	 Switch on the right	
	2	Process actual value 1 (power supply)		
	3	Process actual value 3 (GND)		
	4	Process actual value 2 (compensation)		

1.) Adjustable via Software

Position feedback with proximity switches

Note:

Accessories for upgrading

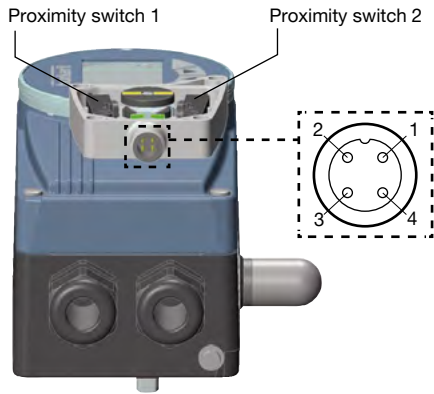

No.	Pin assignment	External circuitry/signal level	
1	Supply 10...30 V	+ 10...30 V	10...30 V
2	Switching output (NO) proximity switches 1	+ 10...30 V	Open/10...30 V
3	GND	GND	GND
4	Switching output (NO) proximity switches 2	+ 10...30 V	Open/10...30 V

Screw terminal connection

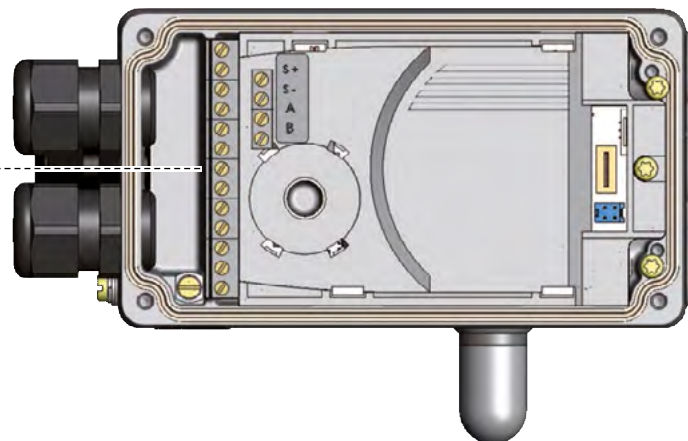
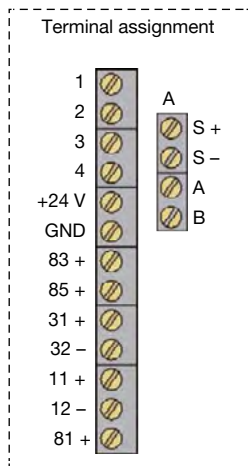

Terminal	Pin assignment	Outer circuitry/Signal level							
11 +	Setpoint +	11 +	+ (0/4...20 mA or 0...5/10 V) Completely galvanically isolated						
12 -	Setpoint GND	12 -	GND						
81 +	Digital input +	81 +	<table border="0"> <tr> <td>+</td> <td></td> <td>0...5 V (log. "0")</td> </tr> <tr> <td></td> <td></td> <td>10...30 V (log. "1")</td> </tr> </table> Relative to operating voltage GND (terminal GND)	+		0...5 V (log. "0")			10...30 V (log. "1")
+		0...5 V (log. "0")							
		10...30 V (log. "1")							
+24 V	Operating voltage +	+24 V	24 V DC ± 10 %						
GND	Operating voltage GND	GND	Maximum residual ripple 10 %						

DTS 1000121144 EN Version: AH Status: RL (released | freigegeben | valide) printed: 07.03.2024

Analogue feedback option/digital outputs

Terminal	Pin assignment	Outer circuitry/Signal level
83 +	Digital outputs 1	83 + 24 V/0 V, NC/NO Relative to operating voltage GND (terminal GND)
85 +	Digital outputs 2	85 + 24 V/0 V, NC/NO Relative to operating voltage GND (terminal GND)
31 +	Analogue feedback +	31 + + (0/4...20 mA or 0...5/10 V) Completely galvanically isolated
32 -	Analogue feedback GND	32 - GND analogue feedback

Remote version option in conjunction with remote position sensor Type 8798

Note:

For variants without remote version: Terminals A, B, S+ and S- not connected

Terminal	Pin assignment	Outer circuitry/Signal level
Remote position sensor	A	Serial interface, A-line
	B	Serial interface, B-line
	S +	Sensor supply +
	S -	Sensor supply -

Terminal assignments of the process actual value - input

Input type ^{1.)}	Terminal	Pin assignment	Outer circuitry
4...20 mA internally supplied	Process actual value	1	+24 V Input Transmitter
		2	Output from transmitter
		3	Bridge according to GND (GND from 3-conductor transmitter)
		4	Not assigned
	GND	GND of operating voltage	
4...20 mA externally supplied	Process actual value	1	Not assigned
		2	Process actual value +
		3	Process actual value -
		4	Not assigned
Frequency internally supplied	Process actual value	1	+24 V Sensor supply
		2	Clock input +
		3	Not assigned
		4	Clock input -
GND	GND of operating voltage		
Frequency externally supplied	Process actual value	1	Not assigned
		2	Clock input +
		3	Not assigned
		4	Clock input -
Pt 100	Process actual value	1	Not assigned
		2	Process actual value 1 (power supply)
		3	Process actual value 3 (GND)
		4	Process actual value 2 (compensation)

1.) Adjustable via software

DTS 1000121144 EN Version: AH Status: RL (released | freigegeben | validé) printed: 07.03.2024

PROFIBUS DP Connection

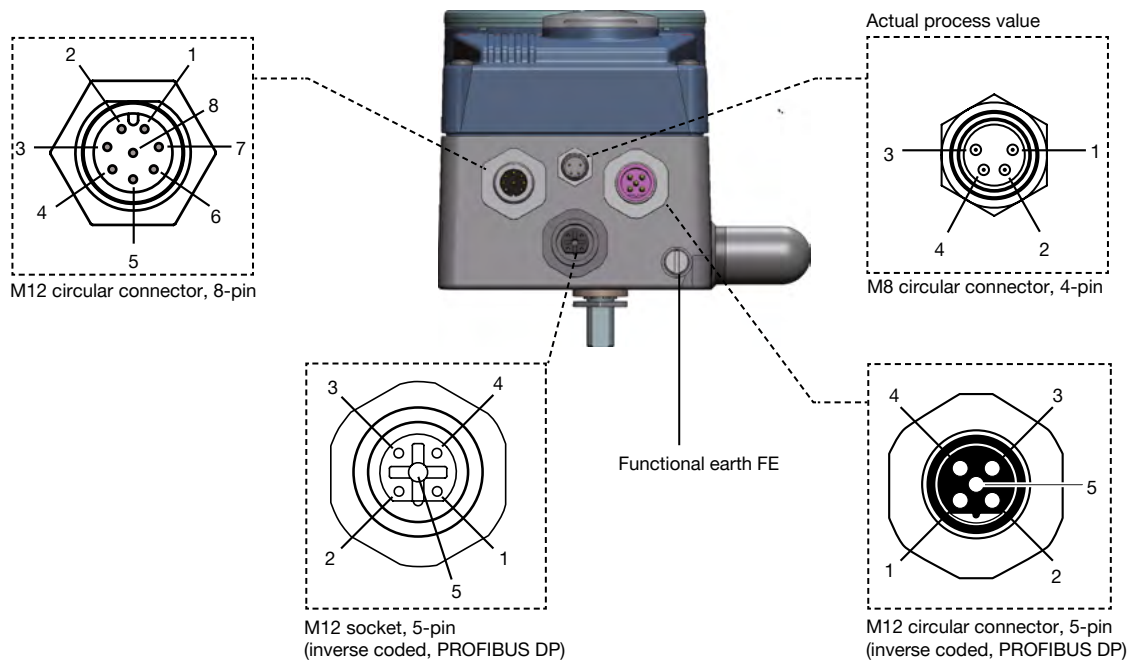

Operating voltage, M12 circular plug, 8-pin

Pin	Pin assignment	Outer circuitry/Signal level	
1	Not assigned		
2	Not assigned		
3	GND	3	 24 V DC ± 10 %
4	+24 V	4	
5	Digital input +		
6	Digital input -		
7	Digital outputs 1 (relative to pin 3)		
8	Digital outputs 2 (relative to pin 3)		

Fieldbus connection, socket/ M12 circular plug, 5-pin

Pin	Pin assignment	Outer circuitry/Signal level
1	VP+ 5	Load resistance supply
2	RxD/TxD-N	Receive/transmit data -N, A-line
3	DGND	Data transfer potential (Ground to 5 V)
4	RxD/TxD-P	Receive/transmit data -P, B-line
5	Shielding	Shielding/functional earth

DTS 1000121144 EN Version: AH Status: RL (released | freigegeben | valide) printed: 07.03.2024

EtherNet/IP, PROFINET, Modbus TCP connection

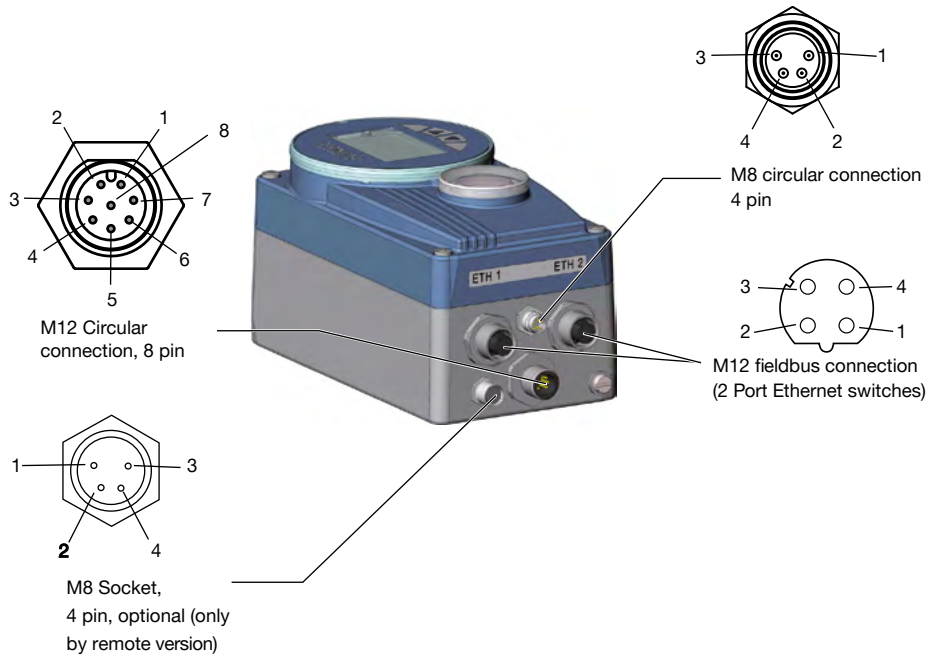

M12 fieldbus connection, D-coded

Connection for EtherNet/IP takes place via M12 circular connector , 4-pin, D-coded

	Pin	Description
	1	Transmit +
	2	Receive +
	3	Transmit -
	4	Receive -

Operating voltage, M12 circular plug, 8-pin

Pin	Pin assignment	Device side	Outer circuitry/Signal level
1	Not assigned		
2	Not assigned		
Operating voltage			
3	GND	3	 24 V DC ± 10 % Maximum residual ripple 10 %
4	+24 V	4	
Input signal of the control centre (e. g. SPS)			
5	Digital input +	5	 0...5 V (log "0") 10...30 V (log "1")
6	Digital input GND	6	GND (identical to pin 3)
Output signal of the control centre (e. g. SPS) (only used with digital outputs option)			
7	Digital outputs 1 (relative to pin 3)	7	0...24 V
8	Digital outputs 2 (relative to pin 3)	8	0...24 V

Connection of digital remote position sensor Type 8798, M8 socket, 4-pin (optional)

Pin	Pin assignment	Outer circuitry/Signal level
1	Sensor supply +	S +
2	Sensor supply -	S -
3	Serial interface, A-line	A
4	Serial interface, B-line	B

DTS 1000121144 EN Version: AH Status: RL (released | freigegeben | validé) printed: 07.03.2024

Bürkert system bus (bùS) connection

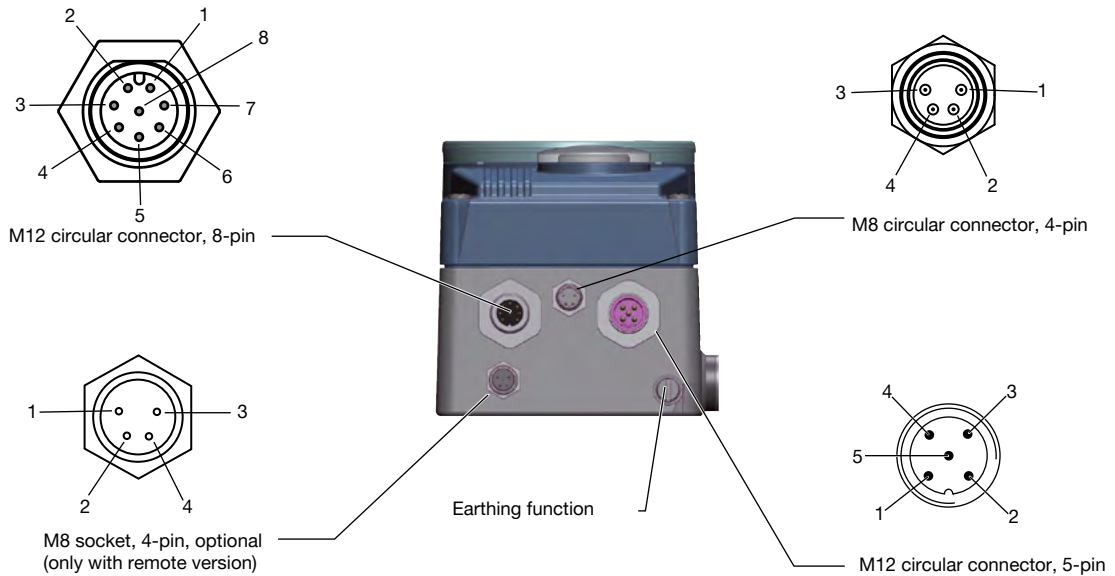

Fieldbus connection M12 x 1 circular plug, 5-pin

Pin	Cable colour	Description
1	CAN Shielding	CAN Shielding
2	Not assigned	
3	Black	GND/CAN_GND
4	White	CAN_H
5	Blue	CAN_L

Operating voltage M12 circular plug, 8-pin

Pin	Pin assignment	Device side	Outer circuitry/Signal level
1	Not assigned		
2	Not assigned		
Operating voltage			
3	GND	3	24 V DC ± 10 %
4	+24 V	4	Maximum residual ripple 10 %
Input signal of the control centre (e. g. SPS)			
5	Digital input +	5	0...5 V (log "0") 10...30 V (log "1")
6	Digital input GND	6	GND (identical to pin 3)
Output signal of the control centre (e. g. SPS) (only used with digital outputs option)			
7	Digital outputs 1 (relative to pin 3)	7	0...24 V
8	Digital outputs 2 (relative to pin 3)	8	0...24 V

Connection of digital remote position sensor Type 8798, M8 socket, 4-pin (optional)

Pin	Pin assignment	Outer circuitry/Signal level
1	Sensor supply +	S +
2	Sensor supply -	S -
3	Serial interface, A-line	A
4	Serial interface, B-line	B

Remote sensor
Type 8798

DTS 1000121144 EN Version: AH Status: RL (released | freigegeben | validé) printed: 07.03.2024

Connection of analogue remote position sensor, M8 socket, 4-pin (optional)

Pin	Pin assignment	On device side	Outer circuitry
1	Potentiometer 1	1	
2	Wiper 2	2	
3	Potentiometer 3	3	
4	Not assigned		

M8 circular plug, 4-pin, process actual value (for Type 8793)

Input type ^{1.)}	Pin	Pin assignment	DIP switch	Outer circuitry
4...20 mA internally supplied	1	+24 V Transmitter supply	<p>Switch on left</p>	
	2	Output from transmitter		
	3	GND identical with GND operating voltage		
	4	Bridge according to GND (GND via 3-wire Transmitter)		
4...20 mA externally supplied	1	Not assigned	<p>Switch on right</p>	
	2	Process actual value +		
	3	Not assigned		
	4	Process actual value -		
Frequency internally supplied	1	+24 V Sensor supply	<p>Switch on left</p>	
	2	Clock input +		
	3	Clock input - (GND identical with GND operating voltage)		
	4	Not assigned		
Frequency externally supplied	1	Not assigned	<p>Switch on right</p>	
	2	Clock input +		
	3	Clock input -		
	4	Not assigned		
Pt 100	1	Not assigned	<p>Switch on right</p>	
	2	Process actual value 1 (power supply)		
	3	Process actual value 3 (GND)		
	4	Process actual value 2 (compensation)		

1.) Adjustable via software

DTS 1000121144 EN Version: AH Status: RL (released | freigegeben | valide) printed: 07.03.2024

5. Performance specifications

5.1. Signal flow diagram

Process control loop

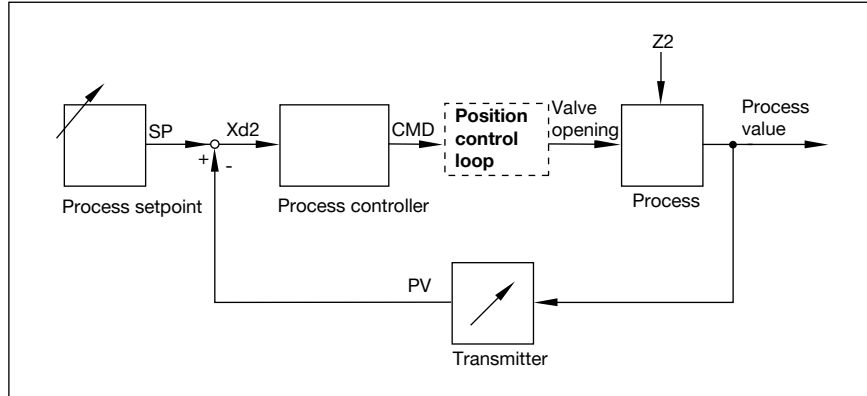

Position control loop

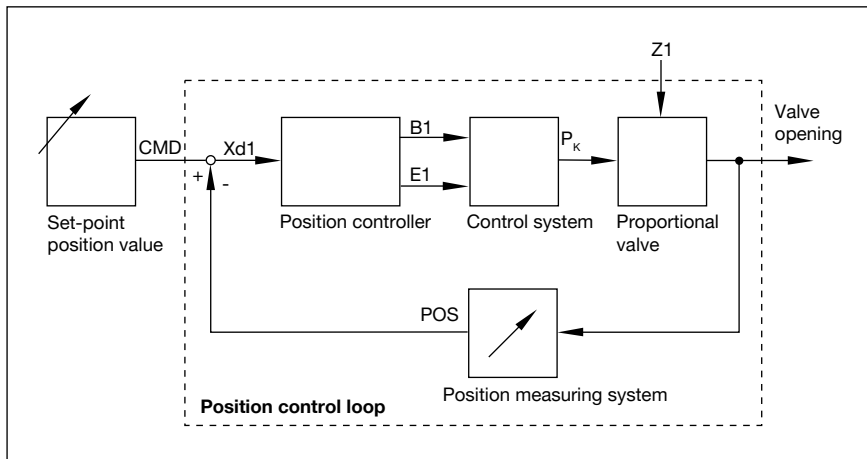

Additional software options of process controller SideControl Type 8793 (extract)

- Automatic commissioning of control system
- Automatic parameterisation of process control loop
- Automatic or manual characteristics curves selection
- Setting of seal and maximum stroke threshold respectively
- Parameterisation of positioner
- Manual parameterisation of process controller
- Limitation of stroke range
- Limitation of manipulating speed
- Setting of moving direction
- Configuration of digital input
- Signal range splitting on several controllers
- Configuration of analogue or 2 digital outputs
- Signal fault detection
- Safety position
- Code protection
- Contrast inversion of display
- Parameterizable diagnostic functions¹⁾/digital outputs (option)

- Operating-hours counter
- Path accumulator
- Position monitoring
- Process actual value monitoring
- Graphical display of dwell time density and movement range
- Monitoring of mechanical end positions in armature

1.) Further diagnostic functions with detailed description can be found in the **operating instructions Type 8793** ▶.

5.2. Interface diagram

Version without fieldbus communication

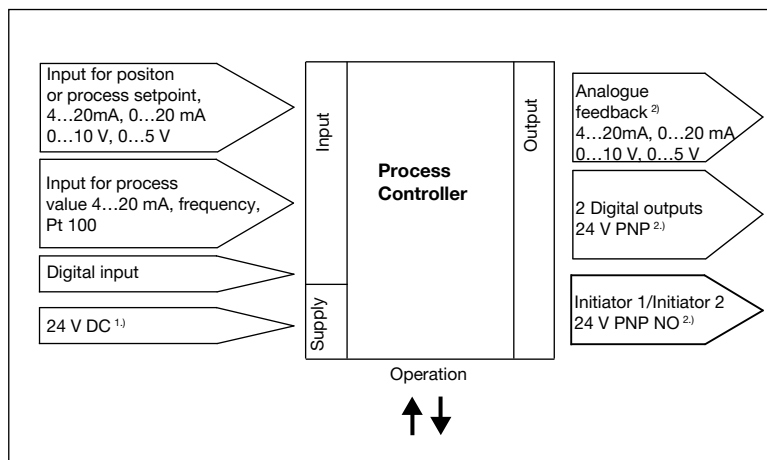

Version with fieldbus communication

PROFIBUS DP, EtherNet/IP, PROFINET, Modbus TCP and Bürkert system bus (büS)

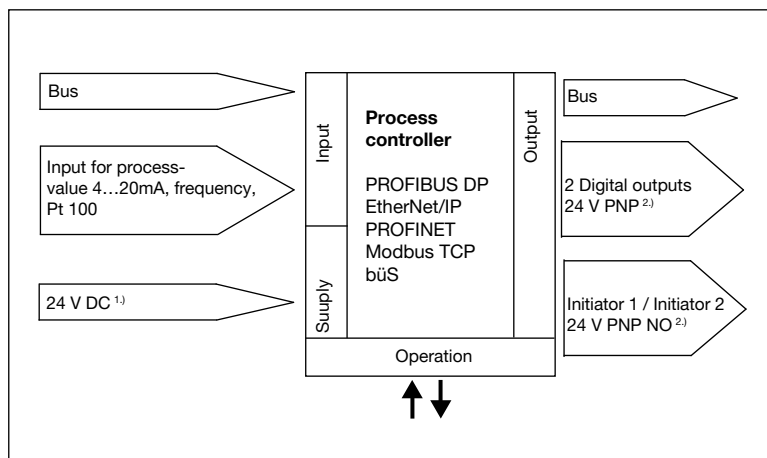

1.) Operating voltage is supplied with a 3-wire unit independent from the setpoint signal

2.) Alternative options

6. Product installation

6.1. Mounting options

NAMUR version

Note:

Positioner with integrated position sensor, installation according to NAMUR/IEC 60534-6-1 and VDI/VDE 3845 (IEC 60534-6-2)

The NAMUR version of the SideControl positioner is equipped with an integrated position sensor (linear or rotary). It has a standardised interface for direct attachment to linear actuators according to NAMUR/IEC 60534-6-1 and VDI/VDE 3845 (IEC 60534-6-2).

Linear actuators	Rotary actuators
See operating manual Type 8793 ▶	See operating manual Type 8793 ▶

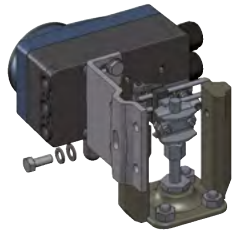

Description	Article no.	Description	Article no.
Mounting kit	787215	Adapter kit	787338
		Mounting bracket	770294

Adapter kit for rotary actuators (Article no. 787338)	Mounting bracket for rotary actuator (Article no. 770294)
--	--

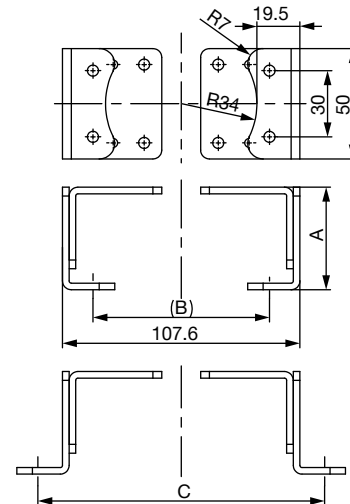
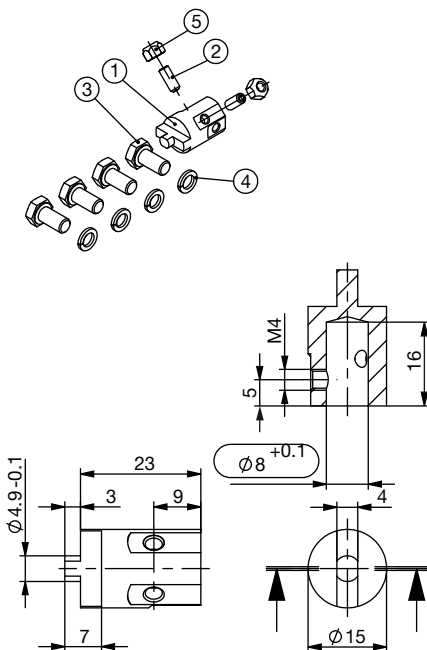

Actuator shaft height [mm]	A [mm]	B [mm]	C [mm]
20	46.5	80	-
30	56.5	80	130
50	76.5	-	130

DTS 1000121144 EN Version: AH Status: RL (released | freigegeben | valide) printed: 07.03.2024



Remote version

Note:

- Dimensions in mm
- 2 mounting options

The SideControl positioner remote version is used to control process control valves in combination with a remote position sensor. The remote position sensor is mounted directly on the valve to detect the valve position. The remote positioner can be mounted on the wall or on a standard rail in a control cabinet.

Wall mounting with accessory bracket

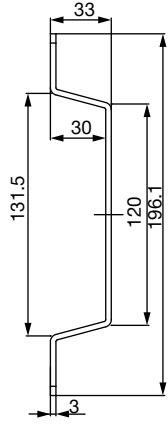
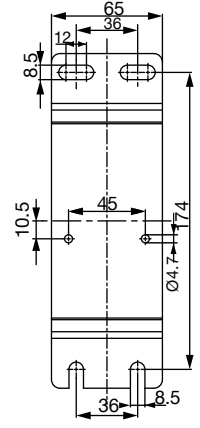





Description	Article no.
Bracket for wall mounting	675715

Mounting on Standard rail

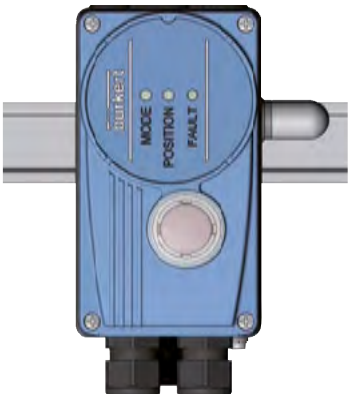
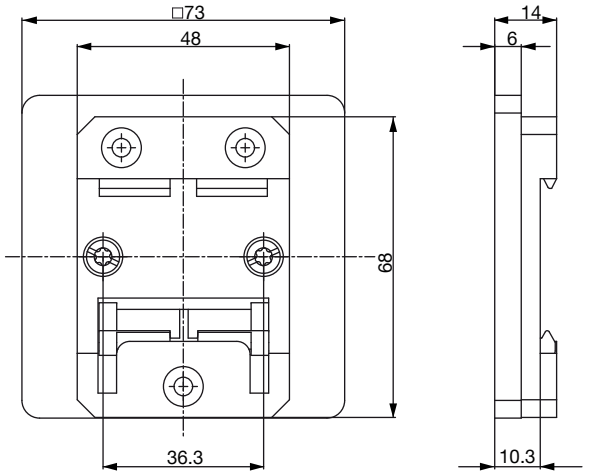
Note:

- Dimensions in mm
- Adapter can be turned by 90° the standard rail.

Description	Article no.
Holder for standard rail mounting	675702

DTS 1000121144 EN Version: AH Status: RL (released | freigegeben | validé) printed: 07.03.2024

Position feedback with proximity switches

Note:



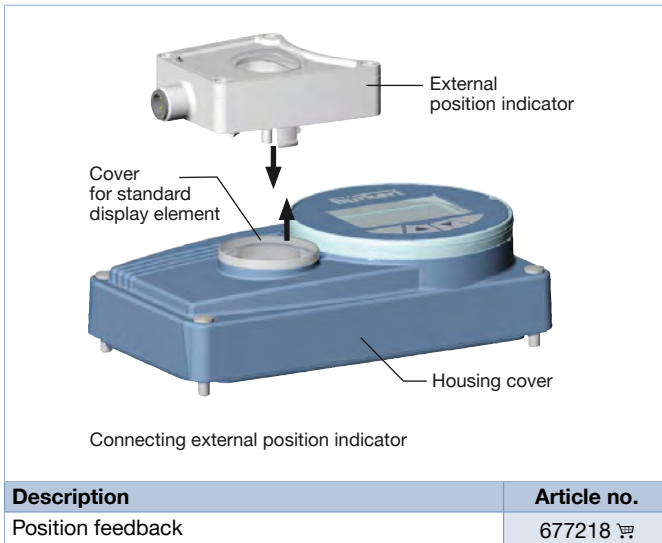

Upgrade feature for SideControl NAMUR



6.2. Combination possibilities with pneumatic process valves

Note:

Further ordering information can be found in chapter “7.3. Ordering chart” on page 29.

Process controller SideControl 8793	8793 NAMUR		8793 Remote		8793 Remote	
						
	<p>Linear actuators IEC 60534 - 6 - 1</p> <p>Rotary actuators VDI/VDE 3845 (IEC 60534 - 6 - 2)</p>		<p>Linear actuators IEC 60534 - 6 - 1</p> <p>Rotary actuators VDI/VDE 3845 (IEC 60534 - 6 - 2)</p>		<p>Control valve system</p>	
	<p>Typ 8805 ▶ Ball valve/Butterfly valve with pneumatic rotary actuator</p>		<p>Typ 8798 ▶ Remote sensor for pneumatically actuated process valves</p>		<p>Typ 2300 ▶ Pneumatically actuated 2-way angle seat control valve ELEMENT + Typ 8798 ▶ Remote sensor for pneumatically actuated process valves</p>	

DTS 1000121144 EN Version: AH Status: RL (released | freigegeben | valide) printed: 07.03.2024

7. Ordering information

7.1. Bürkert eShop



Bürkert eShop – Easy ordering and quick delivery

You want to find your desired Bürkert product or spare part quickly and order directly? Our online shop is available for you 24/7. Sign up and enjoy all the benefits.

[Order online now](#)

7.2. Bürkert product filter

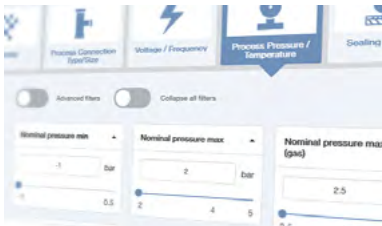

Bürkert product filter – Get quickly to the right product

You want to select products comfortably based on your technical requirements? Use the Bürkert product filter and find suitable articles for your application quickly and easily.

[Try out our product filter](#)

7.3. Ordering chart

Process controller SideControl Type 8793 NAMUR version

Note:

- Mounting according to NAMUR IEC 60534 - 6 - 1 resp. VDI/VDE 3845 (IEC 60534 - 6 - 2)
- Further versions are available on request.

Communication	Electrical connection	Analogue feedback	2 Digital outputs	Diagnos-tics ¹⁾	cCSAus	ATEX II 3 GD/ IECEx CCC ²⁾	Article no.
Single and double-acting with universal air capacity							
Without fieldbus communication	Cable gland	–	–	–	Yes	–	317976
		–	Yes	Yes	Yes	–	317978
		Yes	Yes	Yes	Yes	–	317977
		Yes	Yes	Yes	–	Yes	318040
		–	Yes	Yes	–	Yes	318041
	Multipole	–	–	–	Yes	–	317979
		–	Yes	Yes	Yes	–	317981
		Yes	Yes	Yes	Yes	–	317980
PROFIBUS DP-V1	Multipole	Via bus	–	–	Yes	–	206600
		Via bus	Yes	Yes	Yes	–	206601
EtherNet/IP	Multipole	Via bus	–	Yes	Yes	–	317930
		Via bus	Yes	Yes	Yes	–	317931
PROFINET	Multipole	Via bus	–	Yes	Yes	–	317940
		Via bus	Yes	Yes	Yes	–	317941
Modbus TCP	Multipole	Via bus	–	Yes	Yes	–	317950
		Via bus	Yes	Yes	Yes	–	317951
Bürkert system bus (bùS)	Multipole	Via bus	–	Yes	Yes	–	317960
		Via bus	Yes	Yes	Yes	–	317961

1.) See "Additional software options of process controller SideControl Type 8793 (extract)" on page 23

2.) CCC (China Compulsory Certificate) for device versions with Ex approval

Process controller SideControl Type 8793, remote version

Note:

Further versions are available on request.

Communication	Electrical connection	Analogue feedback	2 Digital outputs	Diagnostics ^{1.)}	cCSAus	ATEX II 3 GD/IECEX CCC ^{2.)}	Article no.
Single-acting with low air capacity for actuator series Type 23xx (Ø70/90 mm)							
Without fieldbus communication	Cable gland	–	–	–	Yes	–	318015
		–	Yes	Yes	Yes	–	318013
		Yes	Yes	Yes	Yes	–	318012
EtherNet/IP	Multipole	Via bus	Yes	Yes	Yes	–	317937
PROFINET		Via bus	Yes	Yes	Yes	–	317947
Modbus TCP		Via bus	Yes	Yes	Yes	–	317957
Bürkert system bus (bÜS)		Via bus	Yes	Yes	Yes	–	317967
Single and double-acting with universal air capacity for actuator series Type 23xx (Ø130/225 mm) and 27xx (Ø175/225 mm)							
Without Fieldbus communication	Cable gland	–	–	–	Yes	–	317982
		Yes	Yes	Yes	Yes	–	317983
		–	Yes	Yes	Yes	–	317984
		Yes	Yes	Yes	–	Yes	318042
EtherNet/IP	Multipole	Via bus	Yes	Yes	Yes	–	317934
PROFINET		Via bus	Yes	Yes	Yes	–	317944
Modbus TCP		Via bus	Yes	Yes	Yes	–	317954
Bürkert system bus (bÜS)		Via bus	Yes	Yes	Yes	–	317964

1.) See "Additional software options of process controller SideControl Type 8793 (extract)" on page 23

2.) CCC (China Compulsory Certificate) for device versions with Ex approval

Remote position sensor for remote version of SideControl Type 8793

Product	Mounting version	Electrical connection	cULus	ATEX II 3 GD/IECEX CCC ^{1.)}	Article no.
Mounting on control valves					
	Control valve Type 23xx	Cable gland - 10 m round cable	Yes	–	300730
		Cable gland - 10 m round cable	–	Yes	20003944
		Multipole - 10 m round cable	Yes	–	307956
	Control valve Type 27xx	Cable gland - 10 m round cable	Yes	–	211535
		Cable gland - 10 m round cable	–	Yes	226859
		Multipole - 10 m round cable	Yes	–	329888
NAMUR mounting					
	NAMUR (rotative)	Cable gland 2 m round cable (extendable to 10 m maximum)	Yes	–	211536

1.) CCC (China Compulsory Certificate) for device versions with Ex approval











DTS 1000121144 EN Version: AH Status: RL (released | freigegeben | validé) printed: 07.03.2024

7.4. Ordering chart accessories

Standard accessories

Note:





The associated communication software can be downloaded under **Type 8793** .

Description	Article no.
M12 circular socket with cable, 8-pin, cable length: 5 m, for input and output signals	919267 
M8 plug, 4-pin for digital outputs, with solder joints	917131 
USB büS interface set 2 (Type 8923) for connection to the Bürkert Communicator software: including büS stick, connection cable to M12 plug, M12 connection cable on micro USB for the büS service interface and Y distributor, cable length: 0.7 m	772551 
büS cable extension, M12, cable length: 1 m	772404 
büS cable extension, M12, cable length: 3 m	772405 
büS cable extension, M12, cable length: 5 m	772406 
büS cable extension, M12, cable length: 10 m	772407 
Silencer G ¼	780780 
USB interface for serial communication	227093 
Software Bürkert Communicator	Type 8920 
AS-Interface flat cable clamp, M12 outlet, stainless steel outlet	799646 

Accessories SideControl NAMUR





Note:

Further information can be found in chapter **“6. Product installation”** on page 25.

Description	Article no.
VDI/VDE 3845 stainless steel universal assembly bridge (IEC60534 -6 -2)	770294 
Attachment kit for stainless steel rotary actuators according to VDI/VDE 3845 (IEC 60534 -6 -2)	787338 
Attachment kit for linear actuators according to IEC 60534 -6 -1	787215 
Position feedback with proximity switches (optional upgrade feature) ^{1.)}	677218 

1.) External end position feedback for upgrading SideControl NAMUR

Accessories SideControl Remote

Description	Article no.
Mounting bracket for stainless steel wall mount (spare part), see “6. Product installation” on page 25	675715 
Standard rail assembly kit aluminium/stainless steel, see “6. Product installation” on page 25	675702 
Attachment kit for Type 21xx/23xx actuator series, actuator size Ø 70/90/130 mm	679917 
Attachment kit for Type 21xx/23xx actuator series, actuator size Ø 225 mm	60025906 
Adapter kit remote sensor, control valves Type 27xx, actuator size Ø 175/225 mm	679945 
Sensor puck (replacement part)	682240 