



Direct-acting 2/2-way plunger valve

- Direct-acting and compact small valve up to DN 2.4
- Slipped over coil system
- Simple and fast flange or manifold mounting
- Quick coupling (push-in fitting) for push-in connectors
- Explosion-proof variants

Product variants described in the data sheet may differ from the product presentation and description.

Type description

The 7011 valve is a direct-acting plunger valve. The stopper and the core guide tube are welded together to increase pressure resistance and leak-tightness. Various housing and seal material combinations are available depending on the actual application. A Bürkert-specific flange variant (SFB) enables the space-saving arrangement of valves on a multiple manifold. The range is supplemented by variants conforming to DVGW EN 161 and explosion-proof variants. Push-in fittings can be selected for a flexible hose connection. In combination with a plug conforming to DIN EN 175301 - 803 shape B, the valves satisfy degree of protection IP65.

Table of contents

1. General technical data	4
1.1. Standard version.....	4
2. Circuit functions	5
3. Approvals and conformities	5
3.1. General notes.....	5
3.2. Conformity	5
3.3. Standards.....	5
3.4. Explosion protection	5
3.5. North America (USA/Canada)	5
3.6. Foods and beverages/Hygiene	6
4. Materials	6
4.1. Bürkert resistApp	6
4.2. Material specifications	6
Standard version circuit function A.....	6
Standard version circuit function B.....	7
5. Dimensions	7
5.1. Standard version.....	7
Threaded version	7
Flange version.....	8
Flange pattern.....	9
5.2. Coil versions.....	10
Versions according to industry standard form B	10
Further electrical connections.....	10
5.3. Single manifold	11
5.4. Multiple manifold.....	12
Manifolds for valves with 20 mm coil (SG2).....	12
Manifolds for valves with 24.5 mm coil (SG3) resp. WW B.....	13
6. Device/Process connections	14
6.1. Pin assignment	14
Pin assignment vacuum applications	14
7. Performance specifications	15
7.1. Power consumption	15
Standard version, coil size 24.5 mm [0.96 in]	15
Standard version, coil size 20 mm [0.79 in]	16
8. Ordering information	17
8.1. Bürkert eShop.....	17
8.2. Bürkert product filter.....	17
8.3. Bürkert Product Enquiry Form	17
8.4. Ordering chart.....	18
Standard version according to industry standard form B, coil size 24.5 mm [0.96 in], coil UL Recognized (cURus)	18
Standard version according to industry standard form B, coil size 20 mm [0.79 in], coil UL Recognized (cURus)	21
Additional options	23

DTS 1000582646 EN Version: B Status: RL (released | freigegeben | validé) printed: 20.03.2024

8.5.	Ordering chart accessories.....	23
	Single manifold	23
	Multiple manifold.....	23
	Accessories for manifolds.....	23
	Cable plug Type 2516, form C according to DIN EN 175301 - 803.....	23
	Cable plug Type 2507, form B according to industry standard	24

1. General technical data

1.1. Standard version

Product properties	
Dimensions	Further information can be found in chapter “5. Dimensions” on page 7.
Material	
Seal	FKM, EPDM
Body	Brass, polyamide (PA), stainless steel 1.4305/303
Manual override	Optional
Weight	
Standard version 24.5 mm solenoid coil	5 ¼ oz (with NPT ½)
Standard version 20 mm solenoid coil	4 ¼ oz (with NPT ½)
Orifice	DN 1.2...DN 2.4
Circuit function	A and B Further information can be found in chapter “2. Circuit functions” on page 5.
Thermal insulation class of solenoid coil	Epoxy coil class H
Performance data	
Nominal operating mode	
Single valve	Continuous operation 100 % ED resp. 50 % ED
For block mounting on multiple manifold	With 4 W/5 W solenoid coil 100 % ED (at max. 131 °F)
Switching time ^{1.)}	Opening 8...15 ms Closing 10...17 ms
Electrical data	
Operating voltage	24 V/DC, 24 V/50 Hz, 24 V/60 Hz, 110 V/50 Hz, 120 V/60 Hz, 230 V/50 Hz, 240 V/60 Hz
Power consumption	Further information can be found in chapter “7. Performance specifications” on page 15.
Voltage tolerance	± 10 %
Medium data	
Operating medium	Neutral gases and fluids (e.g. compressed air, water, hydraulic oil, technical vacuum)
Medium temperature	+ 14 °F...+ 212 °F
Viscosity	Max. 21 cSt
Process/Port connection & communication	
Electrical connection	<ul style="list-style-type: none"> According to DIN EN 175301 - 803 form C for cable plug Type 2516 ▶ Further information can be found in chapter “Cable plug Type 2516, form C according to DIN EN 175301 - 803” on page 23. According to industry standard form B for cable plug Type 2507 ▶ Further information can be found in chapter “Cable plug Type 2507, form B according to industry standard” on page 24. Flat pin terminal as protection class III device Flying leads connection on request for coil size 20 mm
Port connection	M5, G ½, NPT ½, flange
Approvals and conformities	
Degree of protection	IP65 with cable plug and ATEX/IECEx cable version
Explosion protection	Further information can be found in chapter “3.4. Explosion protection” on page 5.
North America (USA/Canada)	Further information can be found in chapter “3.5. North America (USA/Canada)” on page 5.
Foods and beverages/Hygiene	Further information can be found in chapter “3.6. Foods and beverages/Hygiene” on page 6.
Environment and installation	
Installation position	As required, preferably with actuator upright
Ambient temperature	Max. + 131 °F resp. + 167 °F (depending on power level)

1.) Measurement at + 68 °F, 87 psi at the valve outlet acc. to DIN ISO 12238:2001, opening: pressure build-up 0...10 %, closing: pressure reduction 100...90 %

2. Circuit functions

Symbol	Description
	Circuit function A (CF A) 2/2-way solenoid valve Direct-acting Normally closed
	Circuit function B (CF B) 2/2-way solenoid valve Direct-acting Normally open

3. Approvals and conformities

3.1. General notes

- The approvals and conformities listed below must be stated when making enquiries. This is the only way to ensure that the product complies with all required specifications.
- Not all available versions can be supplied with the below mentioned approvals or conformities.

3.2. Conformity

In accordance with the Declaration of Conformity, the product is compliant with the EU Directives.

3.3. Standards

The applied standards which are used to demonstrate compliance with the EU Directives are listed in the EU-Type Examination Certificate and/or the EU Declaration of Conformity.

3.4. Explosion protection

Approval	Description
	Optional: Explosion protection (valid for coils with fixed cable outlet) ATEX: EPS 21 ATEX 1 128 X II 2G Ex mb IIC T4 Gb II 2D Ex mb IIIC T130 °C Db IECEX: IECEx EPS 21.0045X Ex mb IIC T4 Gb Ex mb IIIC T130 °C Db Fixed cable is halogen-free according to IEC 60754 - 1

3.5. North America (USA/Canada)

Approval	Description
	Valid for coils: UL Recognized for the USA and Canada The coils are UL Recognized for the USA and Canada according to: <ul style="list-style-type: none"> • UL 429 (electrically operated valves) • CAN/CSA-C22.2 No. 139

DTS 1000582646 EN Version: B Status: RL (released | freigegeben | valide) printed: 20.03.2024

3.6. Foods and beverages/Hygiene

Conformity	Description
FDA	FDA – Code of Federal Regulations (valid for the variable code PL02, PL03) All wetted materials are compliant with the Code of Federal Regulations published by the FDA (Food and Drug Administration, USA) according to the manufacturer’s declaration.
USP	United States Pharmacopeial Convention (USP) (valid for the variable code PL04) All wetted materials are biocompatible according to the manufacturer’s declaration.
	EC Regulation 1935/2004 of the European Parliament and of the Council (valid for the variable code PL01, PL02) All wetted materials are compliant with EC Regulation 1935/2004/EC according to the manufacturer’s declaration.

4. Materials

4.1. Bürkert resistApp

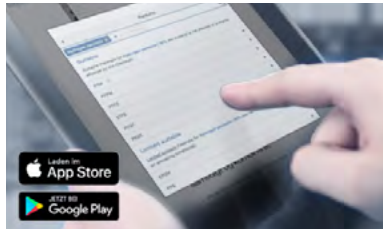

Bürkert resistApp – Chemical resistance chart

You want to ensure the reliability and durability of the materials in your individual application case? Verify your combination of media and materials on our website or in our resistApp.

[Start chemical resistance check](#)

4.2. Material specifications

Standard version circuit function A

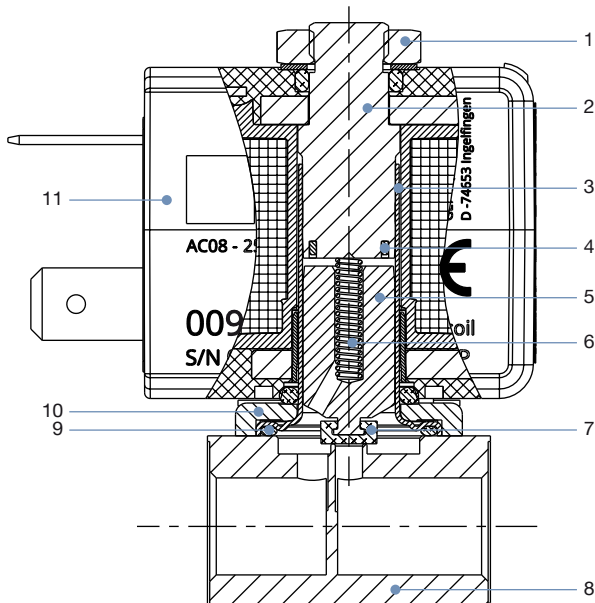

No.	Element	Material
1	Locknut	DIN 176 Surface finish thick film passivated KOSA0101
2	Stopper	Stainless steel 1.4113/434
3	Core guide tube	Stainless steel 1.4303 ST/305L
4	Shading ring	Copper (optional silver)
5	Core	Stainless steel 1.4113/434
6	Spring	Stainless steel 1.4310/301
7	Seal	FKM/EPDM
8	Valve body	Brass, stainless steel 1.4305/303, PA (polyamide)
9	O-Ring	FKM/EPDM
10	Flange	<ul style="list-style-type: none"> Surface finish thick film passivated KOSA0101 (brass version) Nickel-plated surface (stainless steel version)
11	Coil	Epoxy

DTS 1000582646 EN Version: B Status: RL (released | freigegeben | valide) printed: 20.03.2024

Standard version circuit function B

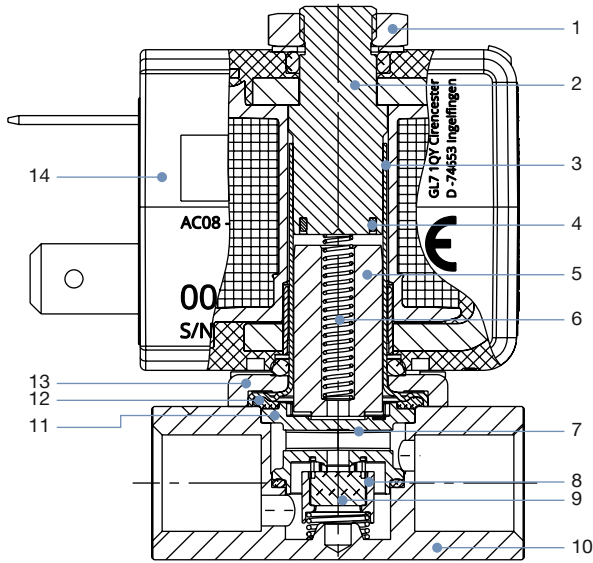

No.	Element	Material
1	Locknut	DIN 176 Surface finish thick film passivated KOSA0101
2	Stopper	Stainless steel 1.4113/434
3	Core guide tube	Stainless steel 1.4303 ST/305L
4	Shading ring	Copper (optional silver)
5	Core	Stainless steel 1.4113/434
6	Spring	Stainless steel 1.4310/301
7	Insert	PEEK GF30
8	Seal holder	PEEK GF30
9	Seat seal	FKM
10	Valve body	Brass, stainless steel 1.4305/303, PA (polyamide)
11	Seal	FKM/EPDM
12	O-Ring	FKM/EPDM
13	Flange	<ul style="list-style-type: none"> Surface finish thick film passivated KOSA0101 (brass version) Nickel-plated surface (stainless steel version)
14	Coil	Epoxy

5. Dimensions

5.1. Standard version

Threaded version

Note:

- Dimensions in mm [inch]
- Versions according to industry standard form B

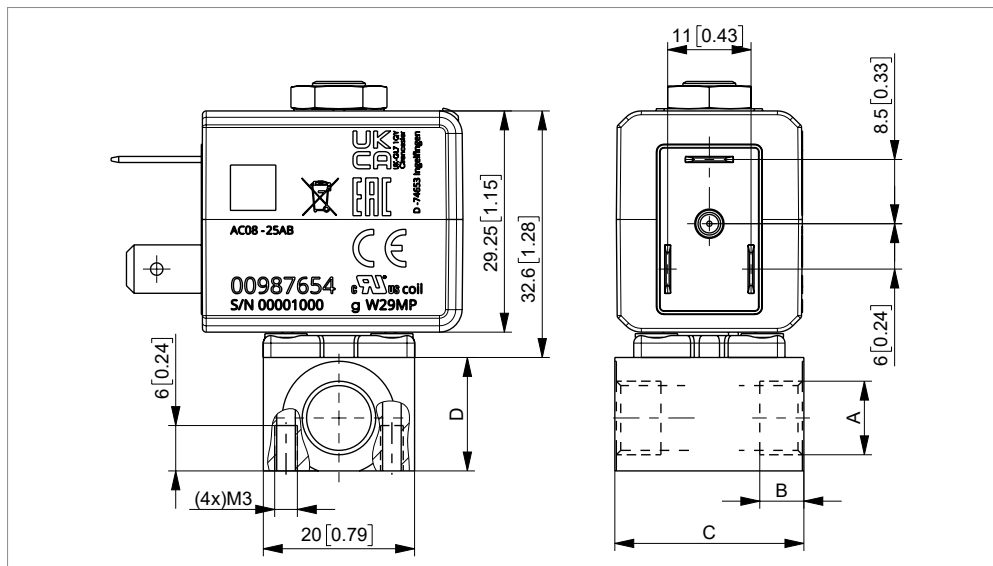

Port connection	A	B		C		D	
		[mm]	[in]	[mm]	[in]	[mm]	[in]
Thread WW A	M5	5	0.19	20	0.78	10	0.39
	G 1/8	8	0.31	25	0.98	15	0.59
	NPT 1/8	7	0.27	25	0.98	15	0.59
Thread WW B	G 1/8	8	0.31	34	1.33	14	0.55
	NPT 1/8	7	0.27	34	1.33	14	0.55

DTS 1000582646 EN Version: B Status: RL (released | freigegeben | valide) printed: 20.03.2024

Flange version

Note:

- Dimensions in mm [inch]
- Versions according to industry standard form B

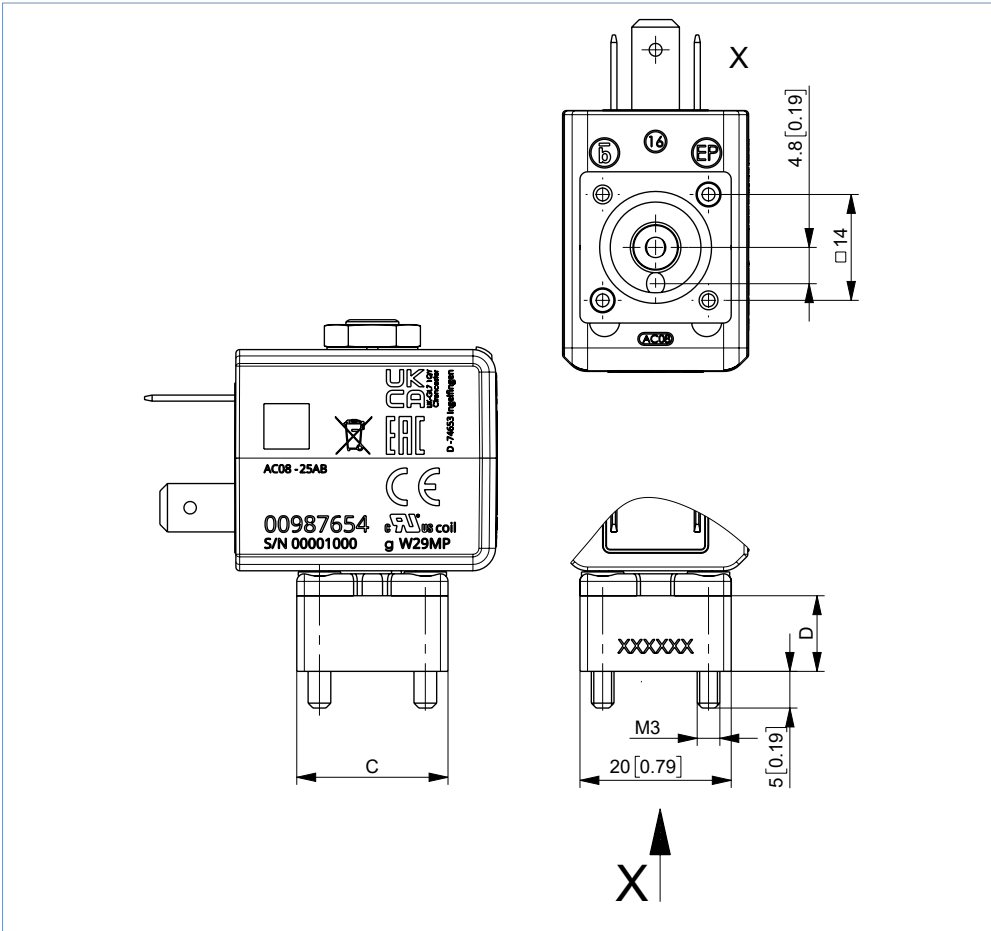

Port connection	A		B		C		D	
	[mm]	[in]	[mm]	[in]	[mm]	[in]	[mm]	[in]
Flange WW A	-	-	-	-	20	0.78	10	0.39
Flange WW B	-	-	-	-	25	0.98	15	0.59

Flange pattern

Note:

- Dimensions in mm [inch]
- On the connection side, the geometries are to be realised as shown in the following drawing.
- Flange version (FK01) according to FST 1000225877

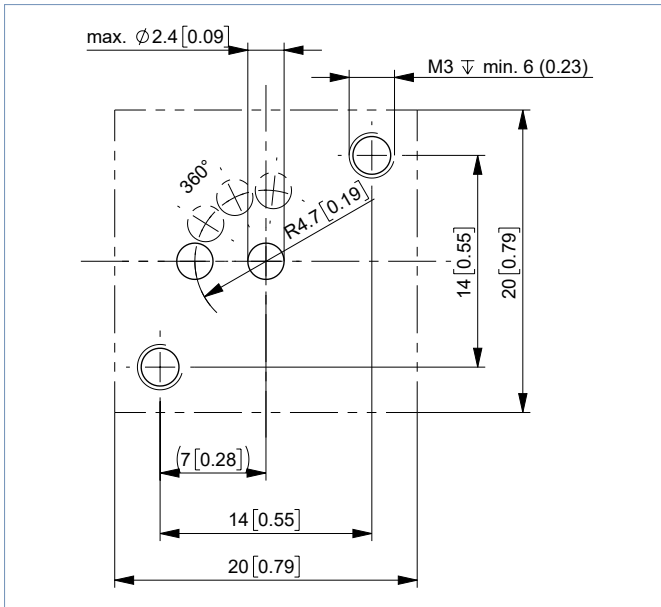

5.2. Coil versions

Versions according to industry standard form B

Note:

Dimensions in mm [inch]

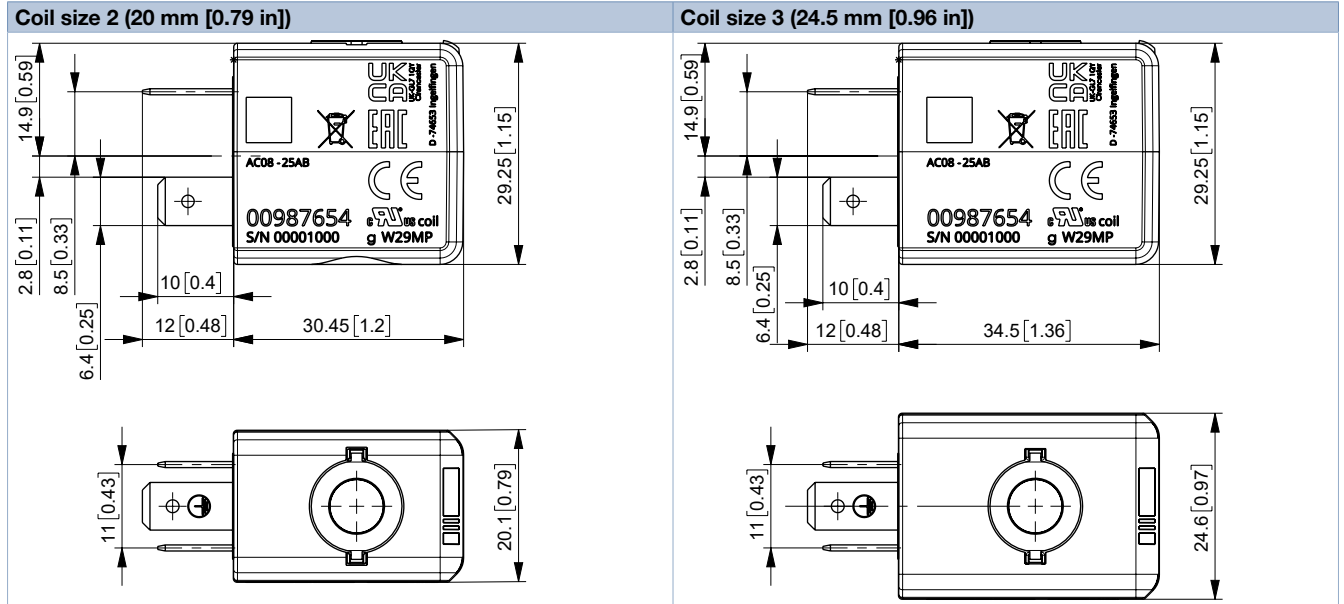

Further electrical connections

Note:

- Dimensions in mm [inch]
- Specifications apply to coil sizes 20 mm [0.79 in] and 24.5 mm [0.96 in]

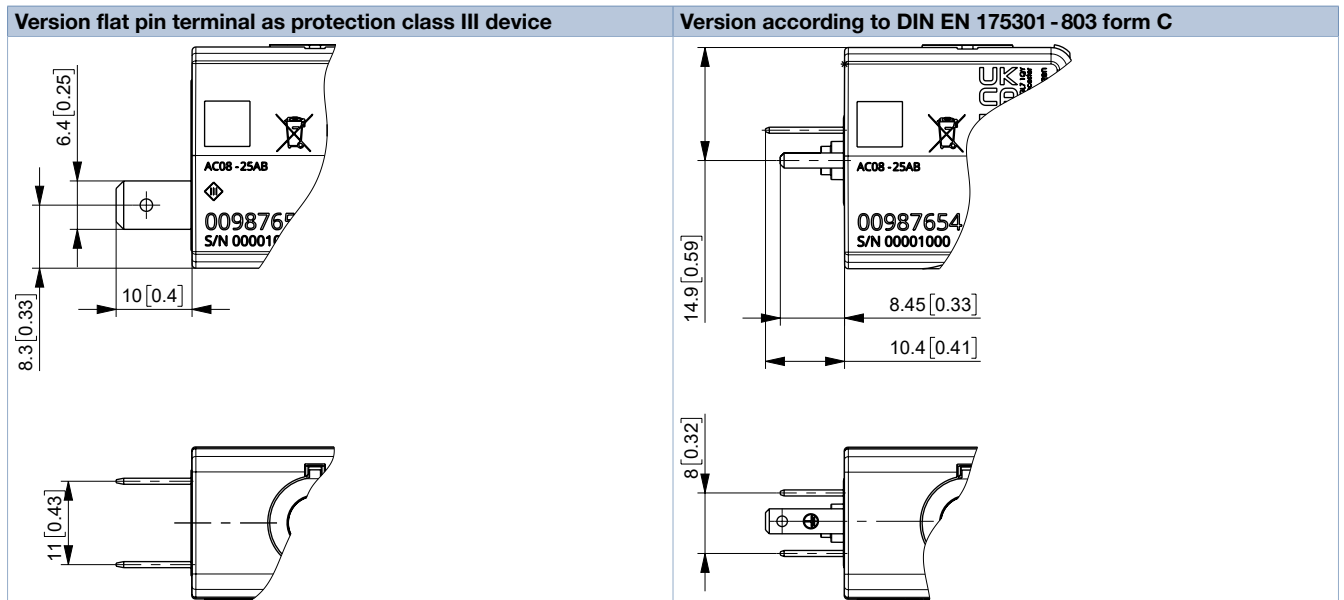

5.3. Single manifold

Note:

Dimensions in mm [inch]

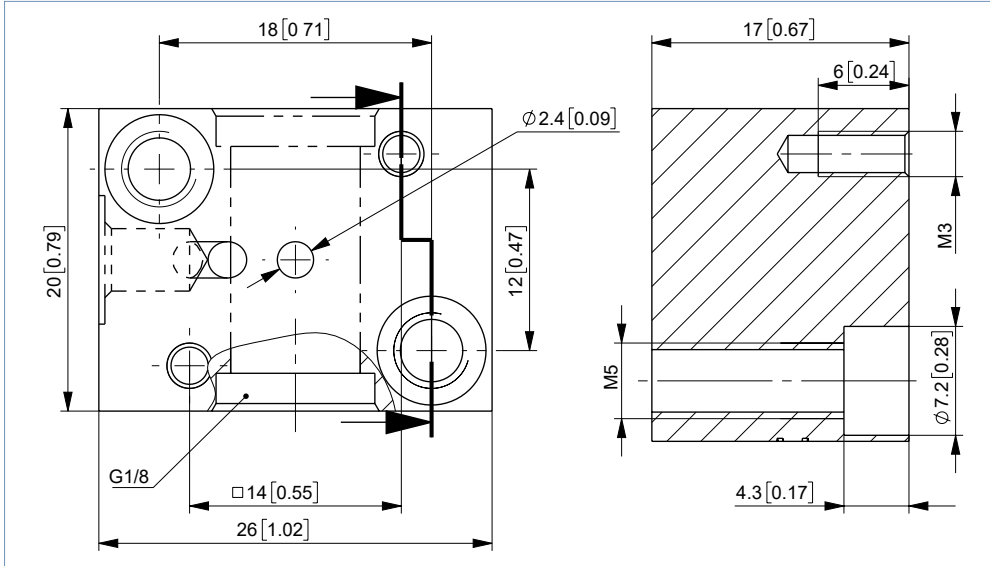

Quantity of valve places	A		B		C		Article no.
	[mm]	[in]	[mm]	[in]	[mm]	[in]	
1	20	0.78	12	0.47	-	-	005312 𐀀

DTS 1000582646 EN Version: B Status: RL (released | freigegeben | validé) printed: 20.03.2024

5.4. Multiple manifold

Manifolds for valves with 20 mm coil (SG2)

Note:

- Dimensions in mm [inch]
- Can only be combined with Type 7011 valves with coil size 20 mm [0.79 in]

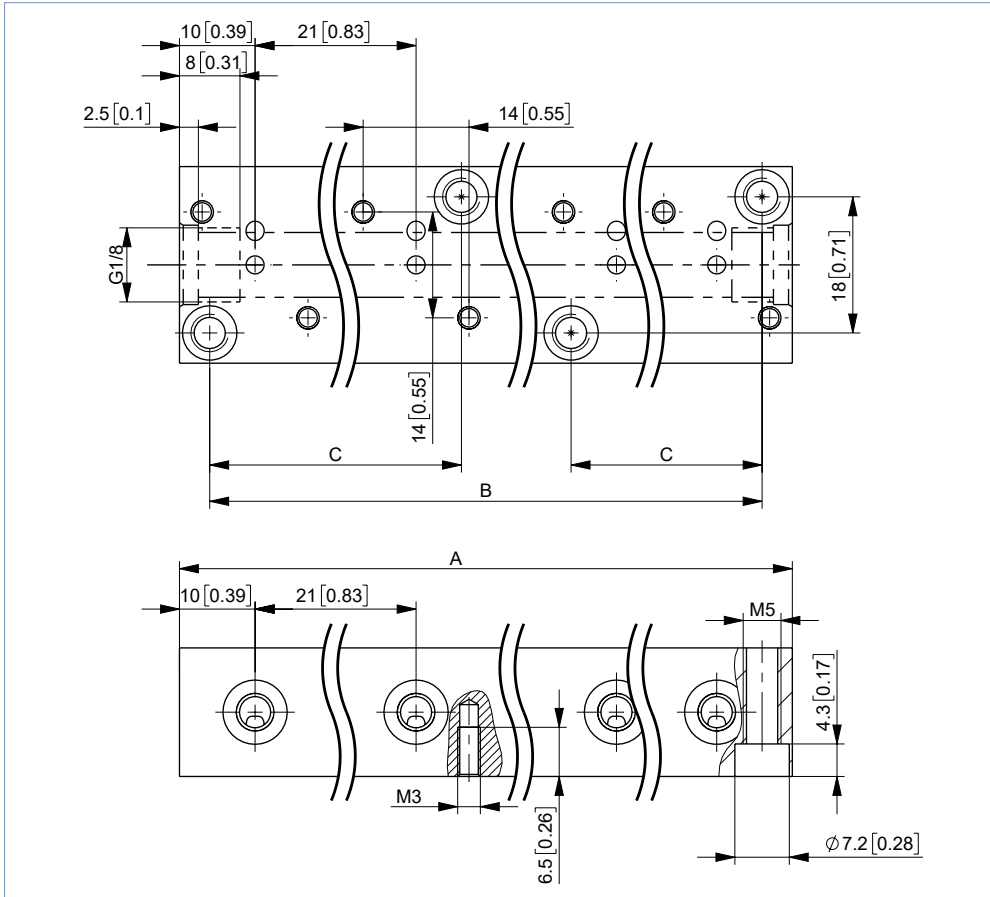

Quantity of valve places	A		B		C		Article no.
	[mm]	[in]	[mm]	[in]	[mm]	[in]	
2	41	1.61	33	1.29	-	-	005355
3	62	2.44	54	2.12	-	-	005313
4	83	3.26	75	2.95	-	-	005314
5	104	4.09	96	3.77	-	-	005315
6	125	4.92	117	4.6	-	-	005316
7	146	5.74	138	5.43	-	-	005893
8	167	6.57	159	6.25	54	2.12	005166
9	188	7.4	180	7.08	54	2.12	005241
10	209	8.22	201	7.91	75	2.95	005819
11	230	9.05	222	8.74	75	2.95	005242
12	251	9.88	243	9.56	96	3.77	005222

DTS 1000582646 EN Version: B Status: RL (released | freigegeben | valide) printed: 20.03.2024

Manifolds for valves with 24.5 mm coil (SG3) resp. WW B

Note:

- Dimensions in mm
- Can only be combined with Type 7011 valves with coil size 24.5 mm [0.965 in] resp. for Type 7011 valves with WW B

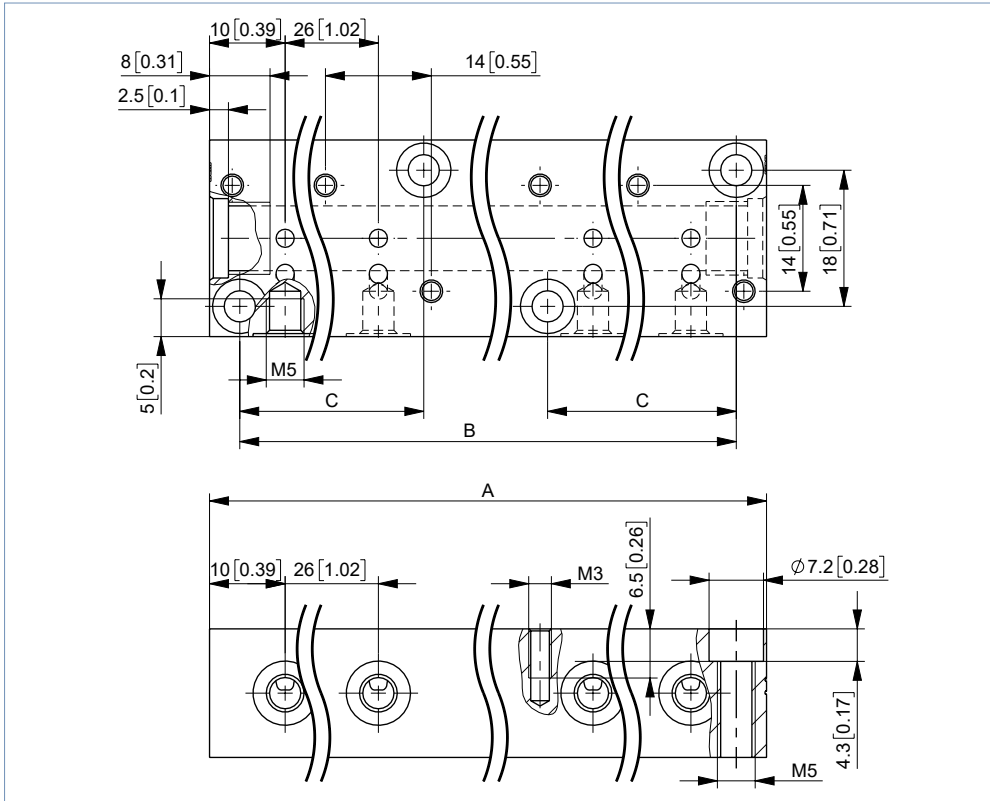

Quantity of valve places	A		B		C		Article no.
	[mm]	[in]	[mm]	[in]	[mm]	[in]	
2	46	1.81	38	1.49	-	-	60021427
3	72	2.83	64	2.51	-	-	60021342
4	98	3.85	90	3.54	-	-	60021429
5	124	4.88	116	4.56	-	-	60021428
6	150	5.9	142	5.59	-	-	60021442
7	176	6.92	168	6.61	-	-	20060327
8	202	7.95	194	7.63	64	2.51	20060338
9	228	8.97	220	8.66	64	2.51	20060341
10	254	10	246	9.67	90	3.54	20015744
11	280	11.02	272	10.7	90	3.54	20060374
12	306	12.04	298	11.73	116	4.56	20060376

DTS 1000582646 EN Version: B Status: RL (released | freigegeben | valide) printed: 20.03.2024

6. Device/Process connections

6.1. Pin assignment

Threaded version WW A	Threaded version WW A (+MC14)	Flange version WW A
Flange version WW A (+MC14)	Flange version WW A (+AA05)	Flange version WW A (+AC45+AD33 / +AD33+NA02)
Threaded version WW B	Flange version WW B	Flange version WW B (+AD01)

Pin assignment vacuum applications

In vacuum applications the existing flow direction must be maintained. Vacuum must therefore always be applied to A.
(Other terminal assignment on request)

7. Performance specifications

7.1. Power consumption

Standard version, coil size 24.5 mm [0.96 in]

Coil	Orifice [mm]	Electrical power					Switching times ^{1.)}	
		Inrush AC [VA]	Hold AC [VA]	[W]	DC Cold [W]	Hot [W]	Opening [ms]	Closing [ms]
24 V/DC/7 W	1.2	–	–	–	7	5.5	8...15	10...17
	1.6							
	2.0							
	2.4							
24 V/50 Hz/6 W	1.2	14	8	6	–	–		
	1.6							
	2.0							
	2.4							
230 V/50 Hz/6 W	1.2	14	8	6	–	–		
	1.6							
	2.0							
	2.4							
24 V/DC/5.5 W	1.2	–	–	–	5.5	4.5		
	1.6							
	2.0							
	2.4							
24 V/50 Hz/4 W	1.2	12	6.5	4	–	–		
	1.6							
	2.0							
	2.4							
230 V/50 Hz/4 W	1.2	12	6.5	4	–	–		
	1.6							
	2.0							
	2.4							
24 V/DC/14 W	1.2	–	–	–	14	11		
	1.6							
	2.0							
	2.4							
24 V/DC/11 W	1.2	–	–	–	11	8.5		
	1.6							
	2.0							
	2.4							

1.) Measurement at +68 °F, 87 psi^{2.)} at the valve outlet acc. to DIN ISO 12238:2001, opening: pressure build-up 0...10 %, closing: pressure reduction 100...90 %

2.) Pressure data: overpressure to atmospheric pressure and air as a medium

Standard version, coil size 20 mm [0.79 in]

Coil	Orifice	Electrical power					Switching times ¹⁾	
		Inrush AC	Hold AC		DC		Opening	Closing
	[mm]	[VA]	[VA]	[W]	Cold [W]	Hot [W]	[ms]	[ms]
24 V/DC/6.5 W	1.2	–	–	–	6.5	5	8...15	10...17
	1.6							
	2.0							
	2.4							
24 V/50 Hz/6 W	1.2	11	7	6	–	–		
	1.6							
	2.0							
	2.4							
230 V/50 Hz/6 W	1.2	11	7	6	–	–		
	1.6							
	2.0							
	2.4							
24 V/DC/5 W	1.2	–	–	–	5	4		
	1.6							
	2.0							
	2.4							
24 V/50 Hz/4 W	1.2	9	5	4	–	–		
	1.6							
	2.0							
	2.4							
230 V/50 Hz/4 W	1.2	9	5	4	–	–		
	1.6							
	2.0							
	2.4							
24 V/DC/14 W	1.2	–	–	–	14	11		
	1.6							
	2.0							
	2.4							
24 V/DC/11 W	1.2	–	–	–	11	9		
	1.6							
	2.0							
	2.4							

1.) Measurement at +68 °F, 87 psi²⁾ at the valve outlet acc. to DIN ISO 12238:2001, opening: pressure build-up 0...10%, closing: pressure reduction 100...90%
 2.) Pressure data: overpressure to atmospheric pressure and air as a medium

DTS 1000582646 EN Version: B Status: RL (released | freigegeben | validé) printed: 20.03.2024

8. Ordering information

8.1. Bürkert eShop



Bürkert eShop – Easy ordering and quick delivery

You want to find your desired Bürkert product or spare part quickly and order directly? Our online shop is available for you 24/7. Sign up and enjoy all the benefits.

[Order online now](#)

8.2. Bürkert product filter



Bürkert product filter – Get quickly to the right product

You want to select products comfortably based on your technical requirements? Use the Bürkert product filter and find suitable articles for your application quickly and easily.

[Try out our product filter](#)

8.3. Bürkert Product Enquiry Form

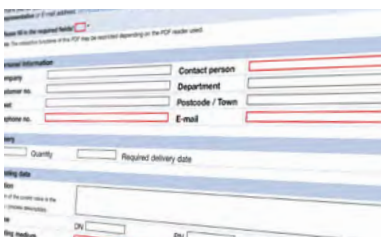

Bürkert Product Enquiry Form – Your enquiry quickly and compactly

Would you like to make a specific product enquiry based on your technical requirements? Use our Product Enquiry Form for this purpose. There you will find all the relevant information for your Bürkert contact. This will enable us to provide you with the best possible advice.

[Fill out the form now](#)

DTS 1000582646 EN Version: B Status: RL (released | freigegeben | validé) printed: 20.03.2024

8.4. Ordering chart

Standard version according to industry standard form B, coil size 24.5 mm [0.96 in], coil UL Recognized (cURus)

Note:

All valves are delivered without a cable plug.

Circuit function	Port connection	Orifice	C _v value water ¹⁾	Voltage/ Frequency/ Power	Maximum duty cycle	Pressure range ²⁾³⁾ (MAWP ⁴⁾)				Article no.				
						Ambient temperature 167 °F		Ambient temperature 131 °F		Brass body	Stainless steel body			
						Water	Air	Water	Air			FKM seal		
[mm]	[gal/min]	[V/Hz/W]	[psi]	[psi]	[psi]	[psi]								
CF A 2/2-way solenoid valve Direct-acting Normally closed 	NPT 1/8	1.2	0.05	24/DC/7	100 % ED	-	-	0...334	0...334	o. r.	o. r.			
				24/60/6		-	-	0...653	0...653	o. r.	o. r.			
				120/60/6		-	-	0...653	0...653	o. r.	o. r.			
				240/60/6		-	-	0...653	0...653	o. r.	o. r.			
				24/DC/5.5		0...232	0...232	-	-	o. r.	o. r.			
				24/DC/5.5		-	-	0...276	0...276	o. r.	o. r.			
				24/60/4		0...609	0...609	0...609	0...609	o. r.	o. r.			
				120/60/4		0...609	0...609	0...609	0...609	o. r.	o. r.			
				240/60/4		0...609	0...609	0...609	0...609	o. r.	o. r.			
				24/DC/14		-	-	0...653	0...653	o. r.	o. r.			
				1.6		0.07	24/DC/7	100 % ED	-	-	0...174	0...189	o. r.	o. r.
							24/60/4		-	-	0...435	0...435	o. r.	o. r.
							120/60/4		-	-	0...435	0...435	o. r.	o. r.
							240/60/4		-	-	0...435	0...435	o. r.	o. r.
							24/DC/5.5		0...131	0...131	-	-	o. r.	o. r.
							24/DC/5.5		-	-	0...152	0...152	o. r.	o. r.
							24/60/4		0...348	0...348	0...348	0...348	o. r.	o. r.
							120/60/4		0...348	0...348	0...348	0...348	o. r.	o. r.
		240/60/4	0...348		0...348		0...348		0...348	o. r.	o. r.			
		24/DC/14	-		-		0...363		0...363	o. r.	o. r.			
		24/DC/11	0...290		0...290		-		-	o. r.	o. r.			
		24/DC/11	-		-		0...319		0...319	o. r.	o. r.			
		2.0	0.13		24/DC/7		100 % ED		-	-	0...131	0...131	o. r.	o. r.
					24/60/4				-	-	0...319	0...319	o. r.	o. r.
					120/60/4				-	-	0...319	0...319	o. r.	o. r.
					240/60/4				-	-	0...319	0...319	o. r.	o. r.
					24/DC/5.5				0...94	0...94	-	-	o. r.	o. r.
					24/DC/5.5				-	-	0...102	0...102	o. r.	o. r.
				24/60/4	0...261	0...261		0...261	0...261	o. r.	o. r.			
				120/60/4	0...261	0...261		0...261	0...261	o. r.	o. r.			
				240/60/4	0...261	0...261		0...261	0...261	o. r.	o. r.			
				24/DC/14	-	-		0...276	0...276	o. r.	o. r.			
				24/DC/11	0...203	0...203		-	-	o. r.	o. r.			
				24/DC/11	-	-		0...232	0...232	o. r.	o. r.			
		2.4	0.15	24/DC/7	100 % ED	-	-	0...51	0...73	o. r.	o. r.			
				24/60/6		-	-	0...189	0...189	o. r.	o. r.			
				120/60/6		-	-	0...189	0...189	o. r.	o. r.			
				240/60/6		-	-	0...189	0...189	o. r.	o. r.			
				24/DC/5.5		0...44	0...51	-	-	o. r.	o. r.			
				24/DC/5.5		-	-	0...51	0...58	o. r.	o. r.			
				24/60/4		0...145	0...145	0...145	0...145	o. r.	o. r.			
				120/60/4		0...145	0...145	0...145	0...145	o. r.	o. r.			
				240/60/4		0...145	0...145	0...145	0...145	o. r.	o. r.			
				24/DC/14		-	-	0...131	0...145	o. r.	o. r.			
				24/DC/11		0...94	0...102	-	-	o. r.	o. r.			
				24/DC/11		-	-	0...109	0...116	o. r.	o. r.			

DTS 1000582646 EN Version: B Status: RL (released | freigegeben | valide) printed: 20.03.2024

Circuit function	Port connection	Orifice	C _v value water ¹⁾	Voltage/ Frequency/ Power	Maximum duty cycle	Pressure range ²⁾³⁾ (MAWP ⁴⁾)				Article no.	
						Ambient temperature 167 °F		Ambient temperature 131 °F		Brass body	Stainless steel body
		Water	Air	Water	Air	FKM seal					
		[psi]	[psi]	[psi]	[psi]						
CF A 2/2-way solenoid valve Direct-acting Normally closed 	Manifold (FK01)	1.2	0.05	24/DC/7	100 % ED	-	-	0...334	0...334	375836	375844
				24/60/6		-	-	0...653	0...653	o. r.	o. r.
				120/60/6		-	-	0...653	0...653	o. r.	o. r.
				240/60/6		-	-	0...653	0...653	o. r.	o. r.
				24/DC/5.5		0...232	0...232	-	-	375868	375876
				24/DC/5.5		-	-	0...276	0...276	o. r.	o. r.
				24/60/4		0...609	0...609	0...609	0...609	o. r.	o. r.
				120/60/4		0...609	0...609	0...609	0...609	o. r.	o. r.
				240/60/4		0...609	0...609	0...609	0...609	o. r.	o. r.
				24/DC/14		-	-	0...653	0...653	o. r.	o. r.
				24/DC/11		0...508	0...508	-	-	o. r.	o. r.
				24/DC/11		-	-	0...537	0...537	o. r.	o. r.
		1.6	0.07	24/DC/7	100 % ED	-	-	0...174	0...189	375837	375845
		24/60/6		-		-	0...435	0...435	o. r.	o. r.	
		120/60/6		-		-	0...435	0...435	o. r.	o. r.	
		240/60/6		-		-	0...435	0...435	o. r.	o. r.	
		24/DC/5.5		0...131		0...131	-	-	375869	375877	
		24/DC/5.5		-		-	0...152	0...152	o. r.	o. r.	
		24/60/4		0...348		0...348	0...348	0...348	o. r.	o. r.	
		120/60/4		0...348		0...348	0...348	0...348	o. r.	o. r.	
		240/60/4		0...348		0...348	0...348	0...348	o. r.	o. r.	
		24/DC/14		-		-	0...363	0...363	o. r.	o. r.	
		24/DC/11		0...290		0...290	-	-	o. r.	o. r.	
		24/DC/11		-		-	0...319	0...319	o. r.	o. r.	
		2.0	0.13	24/DC/7	100 % ED	-	-	0...131	0...131	375838	375846
		24/60/6		-		-	0...319	0...319	o. r.	o. r.	
		120/60/6		-		-	0...319	0...319	o. r.	o. r.	
		240/60/6		-		-	0...319	0...319	o. r.	o. r.	
		24/DC/5.5		0...94		0...94	-	-	375870	375878	
		24/DC/5.5		-		-	0...102	0...102	o. r.	o. r.	
		24/60/4		0...261		0...261	0...261	0...261	o. r.	o. r.	
		120/60/4		0...261		0...261	0...261	0...261	o. r.	o. r.	
		240/60/4		0...261		0...261	0...261	0...261	o. r.	o. r.	
		24/DC/14		-		-	0...276	0...276	o. r.	o. r.	
		24/DC/11		0...203		0...203	-	-	o. r.	o. r.	
		24/DC/11		-		-	0...232	0...232	o. r.	o. r.	
		2.4	0.15	24/DC/7	100 % ED	-	-	0...51	0...73	375839	375847
		24/60/6		-		-	0...189	0...189	o. r.	o. r.	
		120/60/6		-		-	0...189	0...189	o. r.	o. r.	
		240/60/6		-		-	0...189	0...189	o. r.	o. r.	
		24/DC/5.5		0...44		0...51	-	-	375871	375879	
		24/DC/5.5		-		-	0...51	0...58	o. r.	o. r.	
		24/60/4		0...145		0...145	0...145	0...145	o. r.	o. r.	
		120/60/4		0...145		0...145	0...145	0...145	o. r.	o. r.	
		240/60/4		0...145		0...145	0...145	0...145	o. r.	o. r.	
		24/DC/14		-		-	0...131	0...145	o. r.	o. r.	
		24/DC/11		0...94		0...102	-	-	o. r.	o. r.	
		24/DC/11		-		-	0...109	0...116	o. r.	o. r.	

DTS 1000582646 EN Version: B Status: RL (released | freigegeben | valide) printed: 20.03.2024

Circuit function	Port connection	Orifice	C _v value water ^{1.)}	Voltage/ Frequency/ Power	Maximum duty cycle	Pressure range ²⁾³⁾ (MAWP ^{4.)})				Article no.	
						Ambient temperature 167 °F		Ambient temperature 131 °F		Brass body	Stainless steel body
		Water	Air	Water	Air	FKM seal					
		[psi]	[psi]	[psi]	[psi]						
CF B 2/2-way solenoid valve Direct-acting Normally open 	NPT 1/8	2.0	0.12	24/DC/7	100 % ED	-	-	-	0...174	o. r.	o. r.
				24/60/6		-	-	-	0...210	o. r.	o. r.
				120/60/6		-	-	-	0...210	o. r.	o. r.
				240/60/6		-	-	-	0...210	o. r.	o. r.
				24/DC/5.5		-	0...145	-	-	o. r.	o. r.
				24/60/4		-	0...189	-	-	o. r.	o. r.
				120/60/4		-	0...189	-	-	o. r.	o. r.
				240/60/4		-	0...189	-	-	o. r.	o. r.
				240/60/4		-	0...189	-	-	o. r.	o. r.
	Manifold (FK01)	2.0	0.12	24/DC/7	100 % ED	-	-	-	0...174	20009528 𐀀	o. r.
				24/60/6		-	-	-	0...210	o. r.	o. r.
				120/60/6		-	-	-	0...210	o. r.	o. r.
				240/60/6		-	-	-	0...210	o. r.	o. r.
				24/DC/5.5		-	0...145	-	-	20009530 𐀀	o. r.
				24/60/4		-	0...189	-	-	o. r.	o. r.
				120/60/4		-	0...189	-	-	o. r.	o. r.
				240/60/4		-	0...189	-	-	o. r.	o. r.
				240/60/4		-	0...189	-	-	o. r.	o. r.

o. r. = on request

1.) Measurement at +68 °F, 14.5 psi^{2.)} at the valve inlet and free outlet

2.) Pressure data: overpressure to atmospheric pressure and air as a medium

3.) Number of switching cycles under laboratory conditions (FKM seal, oiled air, unpressurised, WW A, DC): 5 million (with WW B less numbers of switching cycles). Please note that an increase in switching pressure can limit the life of the seat seal.

4.) Maximum allowable working pressure

Standard version according to industry standard form B, coil size 20 mm [0.79 in], coil UL Recognized (cURus)

Note:

All valves are delivered without a cable plug.

Circuit function	Port connection	Orifice	C _v value water ¹⁾	Voltage/Frequency/Power	Maximum duty cycle	Pressure range ²⁾³⁾ (MAWP ⁴⁾)		Article no.		
						Ambient temperature 167 °F	Ambient temperature 131 °F	Brass body	Stainless steel body	
		[mm]	[gal/min]	[V/Hz/W]	Air [psi]	Air [psi]	FKM seal			
CF A 2/2-way solenoid valve Direct-acting Normally closed 	NPT 1/8	1.2	0.05	24/DC/6.5	100 % ED	-	0...189	o. r.	o. r.	
				24/60/6		-	0...508	o. r.	o. r.	
				120/60/6		-	0...508	o. r.	o. r.	
				230/50/6		-	0...508	o. r.	o. r.	
				24/DC/5		0...131	-	o. r.	o. r.	
				24/DC/5		-	0...160	o. r.	o. r.	
				24/50/4		0...392	0...392	o. r.	o. r.	
				24/60/4		0...392	0...392	o. r.	o. r.	
				230/50/4		0...392	0...392	o. r.	o. r.	
				24/DC/14		50 % ED	-	0...464	o. r.	o. r.
				24/DC/11			0...363	-	o. r.	o. r.
				24/DC/11			-	0...435	o. r.	o. r.
		1.6	0.07	24/DC/6.5	100 % ED	-	0...123	o. r.	o. r.	
				24/60/6		-	0...348	o. r.	o. r.	
				120/60/6		-	0...348	o. r.	o. r.	
				240/60/6		-	0...348	o. r.	o. r.	
				24/DC/5		0...80	-	o. r.	o. r.	
				24/DC/5		-	0...94	o. r.	o. r.	
				24/60/4		0...247	0...247	o. r.	o. r.	
				120/60/4		0...247	0...247	o. r.	o. r.	
				240/60/4		0...247	0...247	o. r.	o. r.	
				24/DC/14		50 % ED	-	0...319	o. r.	o. r.
				24/DC/11			0...247	-	o. r.	o. r.
				24/DC/11			-	0...261	o. r.	o. r.
		2.0	0.13	24/DC/6.5	100 % ED	-	0...87	o. r.	o. r.	
				24/60/6		-	0...203	o. r.	o. r.	
				120/60/6		-	0...203	o. r.	o. r.	
				240/60/6		-	0...203	o. r.	o. r.	
				24/DC/5		0...58	-	o. r.	o. r.	
				24/DC/5		-	0...65	o. r.	o. r.	
				24/60/4		0...145	0...145	o. r.	o. r.	
				120/60/4		0...145	0...145	o. r.	o. r.	
				240/60/4		0...145	0...145	o. r.	o. r.	
				24/DC/14		50 % ED	-	0...218	o. r.	o. r.
				24/DC/11			0...174	-	o. r.	o. r.
				24/DC/11			-	0...189	o. r.	o. r.
		2.4	0.15	24/DC/6.5	100 % ED	-	0...44	o. r.	o. r.	
				24/60/6		-	0...131	o. r.	o. r.	
				120/60/6		-	0...131	o. r.	o. r.	
				240/60/6		-	0...131	o. r.	o. r.	
				24/DC/5		0...29	-	o. r.	o. r.	
				24/DC/5		-	0...36	o. r.	o. r.	
				24/60/4		0...94	0...94	o. r.	o. r.	
				120/60/4		0...94	0...94	o. r.	o. r.	
				240/60/4		0...94	0...94	o. r.	o. r.	
				24/DC/14		50 % ED	-	0...116	o. r.	o. r.
				24/DC/11			0...87	-	o. r.	o. r.
				24/DC/11			-	0...94	o. r.	o. r.

DTS 1000582646 EN Version: B Status: RL (released | freigegeben | valide) printed: 20.03.2024

Circuit function	Port connection	Orifice	C _v value water ^{1.)}	Voltage/Frequency/Power	Maximum duty cycle	Pressure range ^{2.)3.)} (MAWP ^{4.)})		Article no.		
						Ambient temperature 167 °F	Ambient temperature 131 °F	Brass body	Stainless steel body	
		[mm]	[gal/min]	[V/Hz/W]		Air [psi]	Air [psi]	FKM seal		
CF A 2/2-way solenoid valve Direct-acting Normally closed 	Manifold (FK01)	1.2	0.05	24/DC/6.5	100 % ED	-	0...189	o. r.	o. r.	
				24/60/6		-	0...508	o. r.	o. r.	
				120/60/6		-	0...508	o. r.	o. r.	
				230/50/6		-	0...508	o. r.	o. r.	
				24/DC/5		0...131	-	o. r.	o. r.	
				24/DC/5		-	0...160	o. r.	o. r.	
				24/50/4		0...392	0...392	o. r.	o. r.	
				24/60/4		0...392	0...392	o. r.	o. r.	
				230/50/4		0...392	0...392	o. r.	o. r.	
				24/DC/14		50 % ED	-	0...464	o. r.	o. r.
				24/DC/11		0...363	-	o. r.	o. r.	
				24/DC/11		-	0...435	o. r.	o. r.	
		1.6	0.07	24/DC/6.5	100 % ED	-	0...123	o. r.	o. r.	
				24/60/6		-	0...348	o. r.	o. r.	
				120/60/6		-	0...348	o. r.	o. r.	
				240/60/6		-	0...348	o. r.	o. r.	
				24/DC/5		0...80	-	o. r.	o. r.	
				24/DC/5		-	0...94	o. r.	o. r.	
				24/60/4		0...247	0...247	o. r.	o. r.	
				120/60/4		0...247	0...247	o. r.	o. r.	
				240/60/4		0...247	0...247	o. r.	o. r.	
				24/DC/14		50 % ED	-	0...319	o. r.	o. r.
				24/DC/11		0...247	-	o. r.	o. r.	
				24/DC/11		-	0...261	o. r.	o. r.	
		2.0	0.13	24/DC/6.5	100 % ED	-	0...87	o. r.	o. r.	
				24/60/6		-	0...203	o. r.	o. r.	
				120/60/6		-	0...203	o. r.	o. r.	
				240/60/6		-	0...203	o. r.	o. r.	
				24/DC/5		0...58	-	o. r.	o. r.	
				24/DC/5		-	0...65	o. r.	o. r.	
				24/60/4		0...145	0...145	o. r.	o. r.	
				120/60/4		0...145	0...145	o. r.	o. r.	
				240/60/4		0...145	0...145	o. r.	o. r.	
				24/DC/14		50 % ED	-	0...218	o. r.	o. r.
				24/DC/11		0...174	-	o. r.	o. r.	
				24/DC/11		-	0...189	o. r.	o. r.	
		2.4	0.15	24/DC/6.5	100 % ED	-	0...44	o. r.	o. r.	
				24/60/6		-	0...131	o. r.	o. r.	
				120/60/6		-	0...131	o. r.	o. r.	
				240/60/6		-	0...131	o. r.	o. r.	
				24/DC/5		0...29	-	o. r.	o. r.	
				24/DC/5		-	0...36	o. r.	o. r.	
				24/60/4		0...94	0...94	o. r.	o. r.	
				120/60/4		0...94	0...94	o. r.	o. r.	
				240/60/4		0...94	0...94	o. r.	o. r.	
				24/DC/14		50 % ED	-	0...116	o. r.	o. r.
				24/DC/11		0...87	-	o. r.	o. r.	
				24/DC/11		-	0...94	o. r.	o. r.	

o. r. = on request

1.) Measurement at +68 °F, 14.5 psi^{2.)} at the valve inlet and free outlet

2.) Pressure data: overpressure to atmospheric pressure and air as a medium

3.) Number of switching cycles under laboratory conditions (FKM seal, oiled air, unpressurised, DC): 5 million. Please note that an increase in switching pressure can limit the life of the seat seal.

4.) Maximum allowable working pressure

DTS 1000582646 EN Version: B Status: RL (released | freigegeben | validé) printed: 20.03.2024

Additional options

Note:
Available on request

Option	Variable Code	Description
Oxygen versions	NL02	Suitable for applications with oxygen (non-metal materials that are in contact with the medium are tested and approved according to BAM)
Increased purity requirements e.g. oil, grease and silicone-free	NL50/NL05	Wetted parts are specially cleaned and packaged in accordance with the valves
Increased tightness requirements	PC05	Leakage rate *less than 10^{-4} mbar l/sec
	PC08	Leakage rate *less than 10^{-5} mbar l/sec
	PC06	Leakage rate *less than 10^{-6} mbar l/sec

8.5. Ordering chart accessories

Single manifold

Note:
Further ordering information can be found in chapter “7. Performance specifications” on page 15.

Multiple manifold

Note:
Further ordering information can be found in chapter “5.4. Multiple manifold” on page 12.

Accessories for manifolds

Accessory	Features	Article no.
Screw plug	With sealing ring, G 1/8	005041
Cover plate	For unoccupied valve position	005100

Cable plug Type 2516, form C according to DIN EN 175301 - 803

- Note:**
- Delivery of cable plug includes a flat seal and a fixing screw.
 - For further versions see data sheet **Type 2516**

Cable plug	Dimensions	Version	Voltage	Article no.
		Without circuitry	0...250 V AC/DC	303141
		With LED	12...24 V AC/DC	303145
		With LED and varistor	12...24 V AC/DC	303148
		With rectifier, LED and varistor	12...24 V AC/DC	303142

DTS 1000582646 EN Version: B Status: RL (released | freigegeben | validé) printed: 20.03.2024

Cable plug Type 2507, form B according to industry standard

Note:

- Delivery of cable plug includes a flat seal and a fixing screw.
- Refer to data sheet **Type 2507** ▶ for more information about the cable plug.

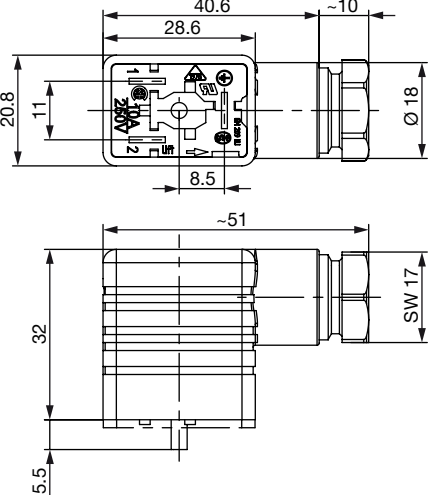
Cable plug	Dimensions	Version	Voltage	Article no.
		Without circuitry (standard)	2...250 V AC/DC	423845
		With LED	24 V AC/DC	423849
		With LED and free-wheeling diode	12...24 V AC/DC	423851
		With rectifier, LED and varistor	12...24 V AC/DC	423853
			2...250 V AC/DC	423854

DTS 1000582646 EN Version: B Status: RL (released | freigegeben | validé) printed: 20.03.2024